

# Air Travel

## Empowerment through Preparation

*My Wheelchair and I are Always One Until We Travel by Air*

Peter W. Axelson MSME, ATP, RET

Beneficial Designs, Inc.  
Minden, Nevada

PVA  
25 June 2025



Reservations



Preparation



Airport Arrival and Parking



Ticket Counter



Security



Departure Gate



Ramp Agent Meeting





Transfer from Wheelchair



Wheelchair Preparation to Fly



Wheelchair's Journey into Aircraft



Passenger Boarding



Connections and Arrival



Mishandling



The future



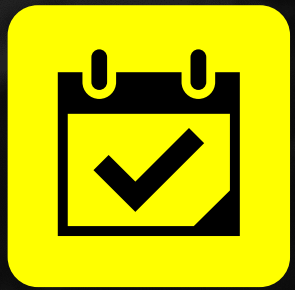

# Reservations

# Research Considerations - online

Length of flight related to bathroom access

Wheelchair dimensions – Wheelchair ID

Aircraft type determines:

Aisle width and

Baggage door size



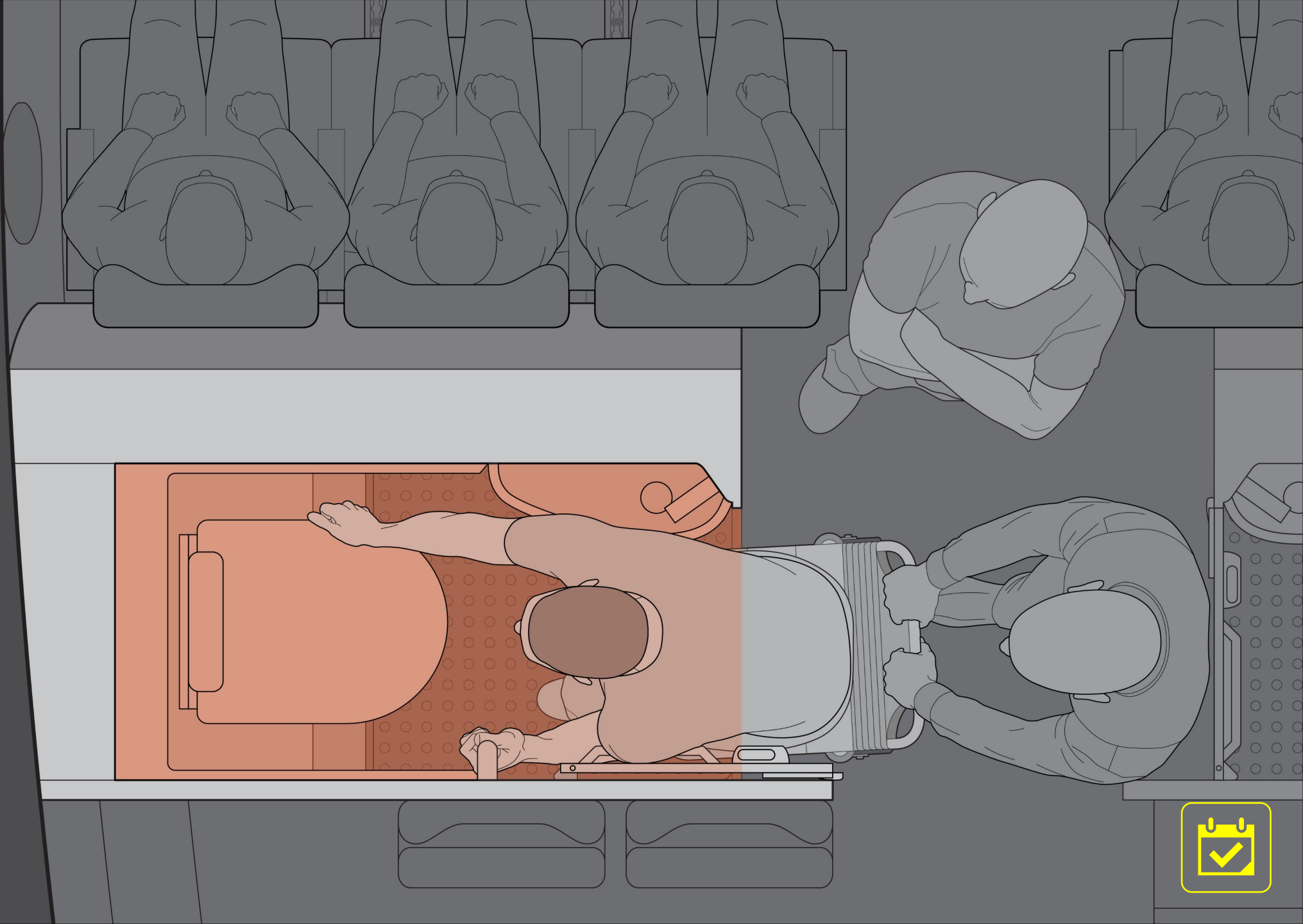

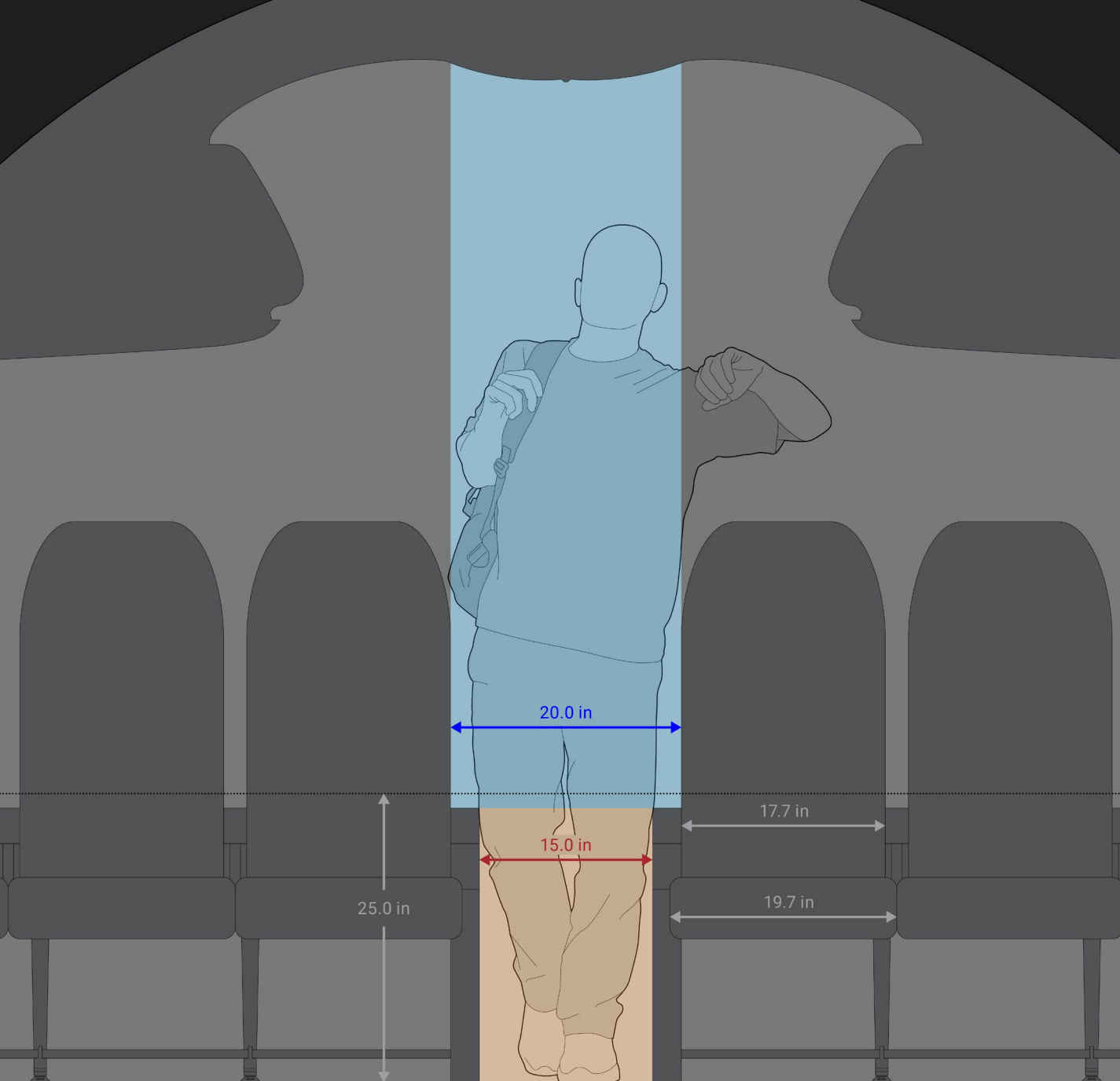

**74.2 in height**

95<sup>th</sup> percentile  
US Male





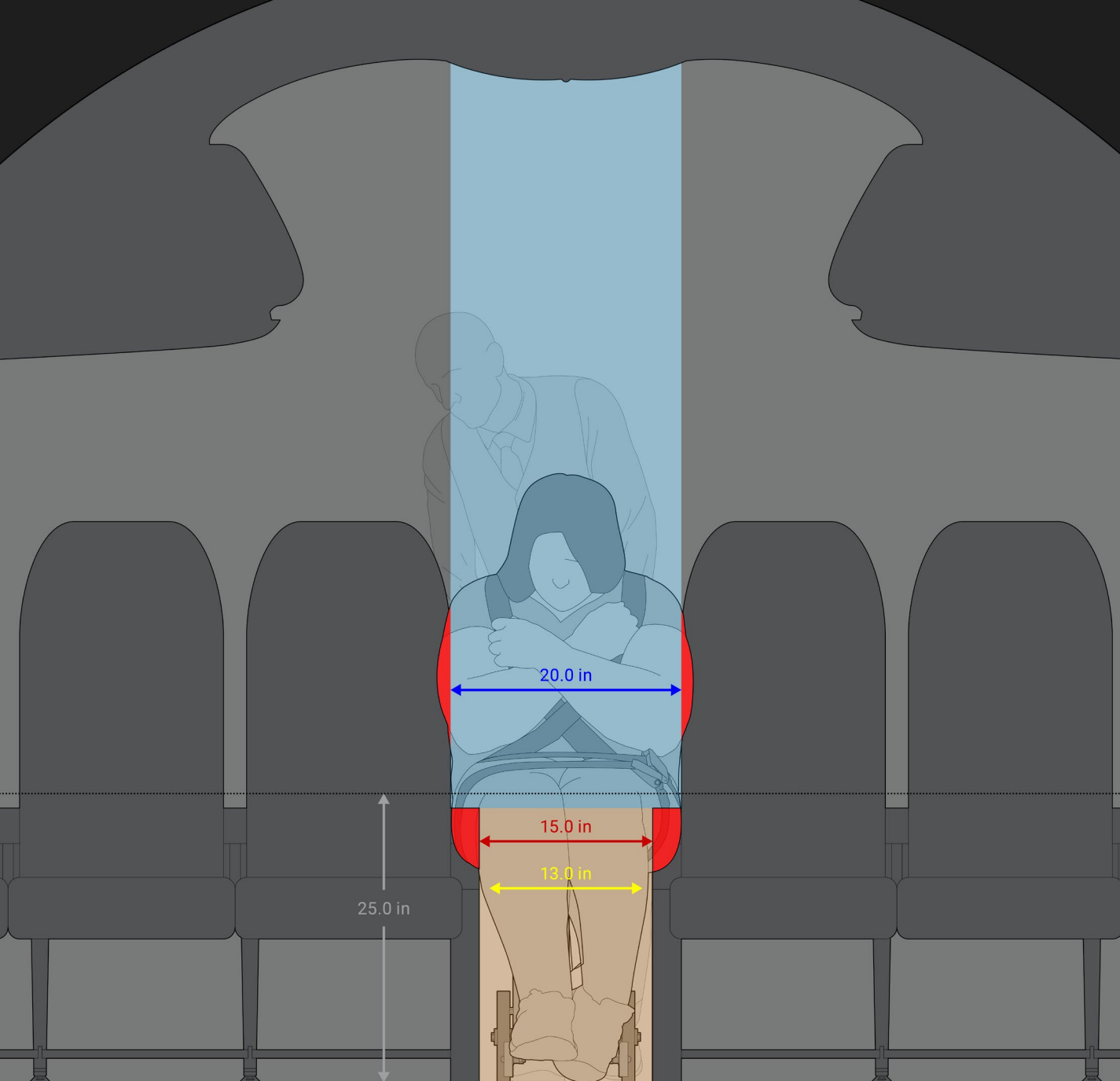

**19.8 in hip width**

95<sup>th</sup> percentile  
US Female



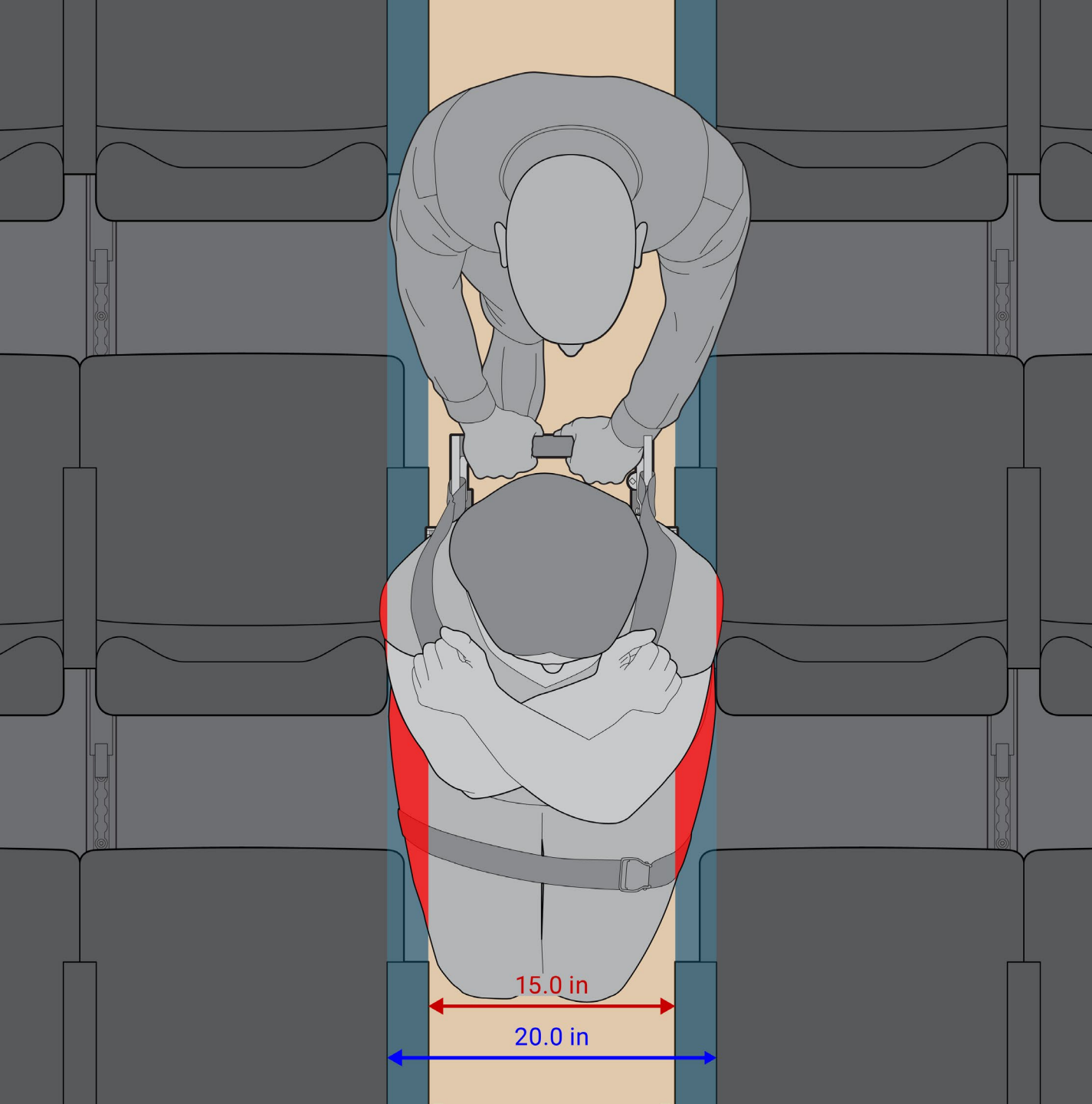

**19.8 in hip width**

95<sup>th</sup> percentile  
US Female



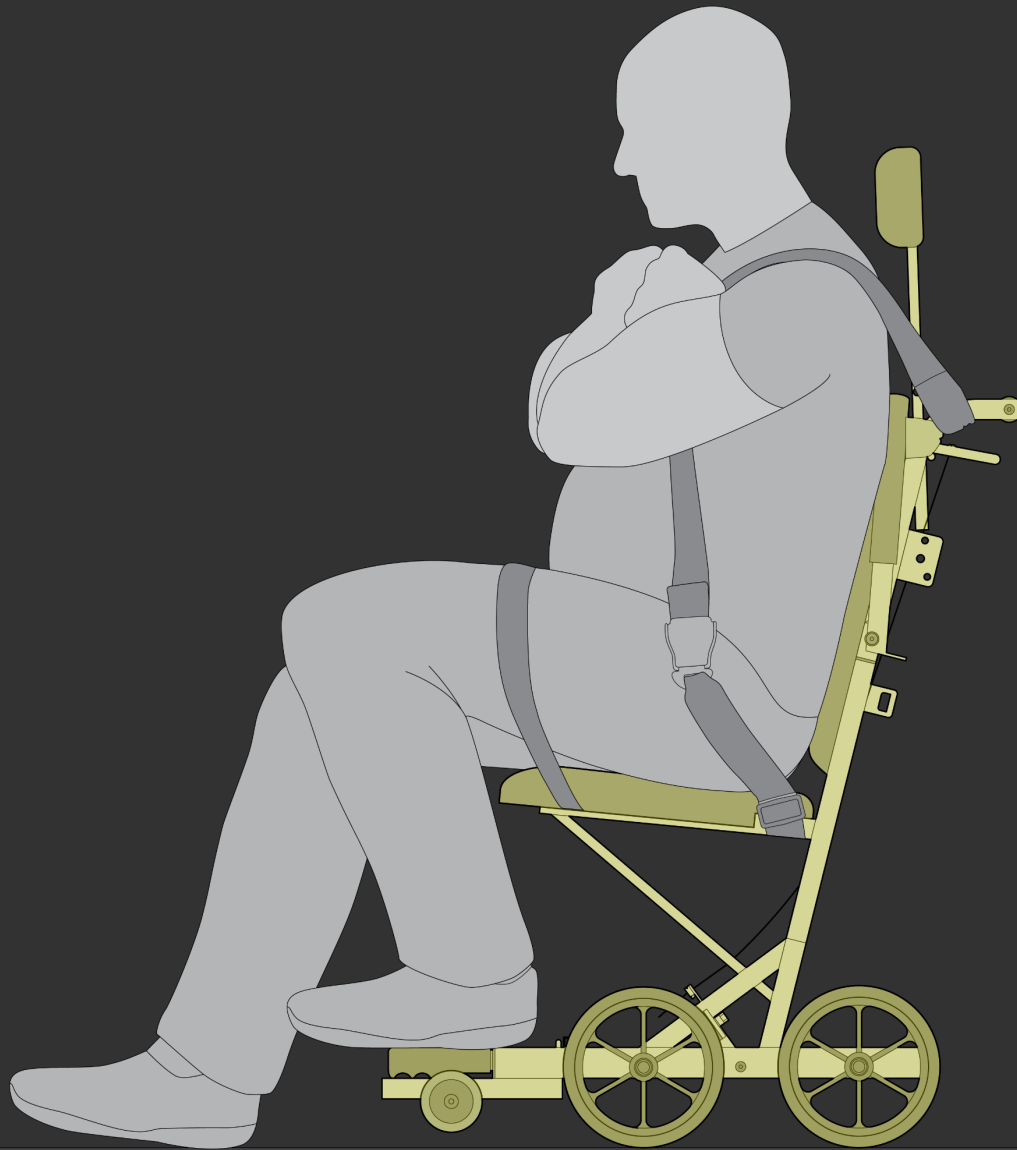

## Device Comparison

95<sup>th</sup> percentile  
US Male





# Talk to the carrier over the phone

Make reservation first

Call and ask for the accessibility expert

Specify seating preferences

Specify assistance needed





## Mobility device

# Air travel information

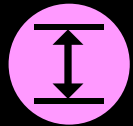

**Size:** length, width, height



**Weight:** total unoccupied mass



**Battery type**





**13 in. x 36 in. x 42 in.**

**WheelchairTravel.org**

<https://wheelchairtravel.org/air-travel/flying-with-manual-wheelchair/>



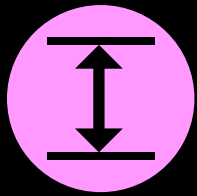

## Mobility device air travel information

**Size:** length, width, height

The height of the mobility device in its air travel configuration must be able to fit through the baggage door (33 in. in many aircraft) and inside the cargo area where it may be secured

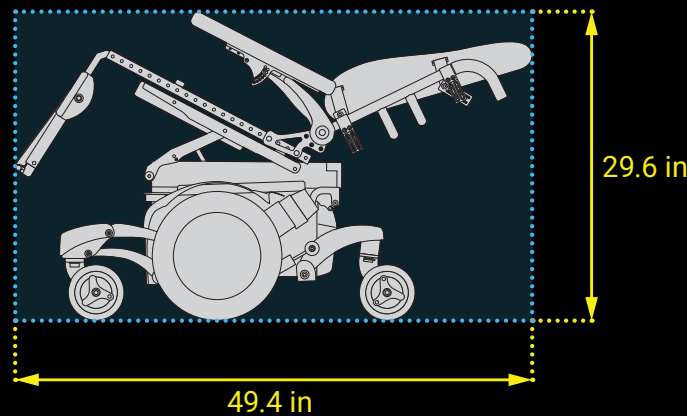

**Air Travel Configuration**

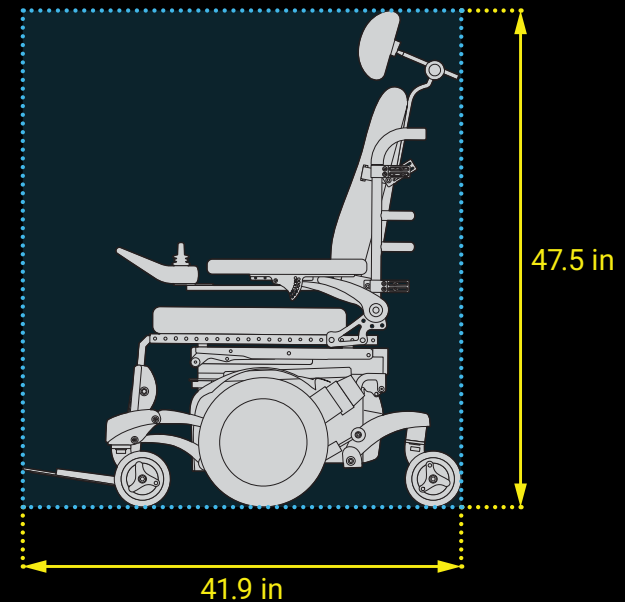

**Driving Configuration**





## Mobility device air travel information

**Weight:** total unoccupied weight

The weight of the mobility device will determine how to load the PMD into the aircraft

Mechanical lift vs manual lifting





## Mobility device air travel information

### Battery type

**Non-spillable required by RESNA WC standards**

The following information is required:

Number of batteries

Battery chemistry

Access location

Nominal voltage

Watt-hour rating if Lithium



# Non-spillable Lead-acid battery



# Spillable battery

Maintenance-free batteries are spillable



<https://upgradedhome.com/how-to-dispose-of-battery-acid/>



# Tool-free access

to inspect battery type



<https://experience.pridemobility.com/electric-wheelchairs/faqs-for-electric-wheelchairs/how-to-charge-your-electric-wheelchair-batteries/>



# Tool-free access

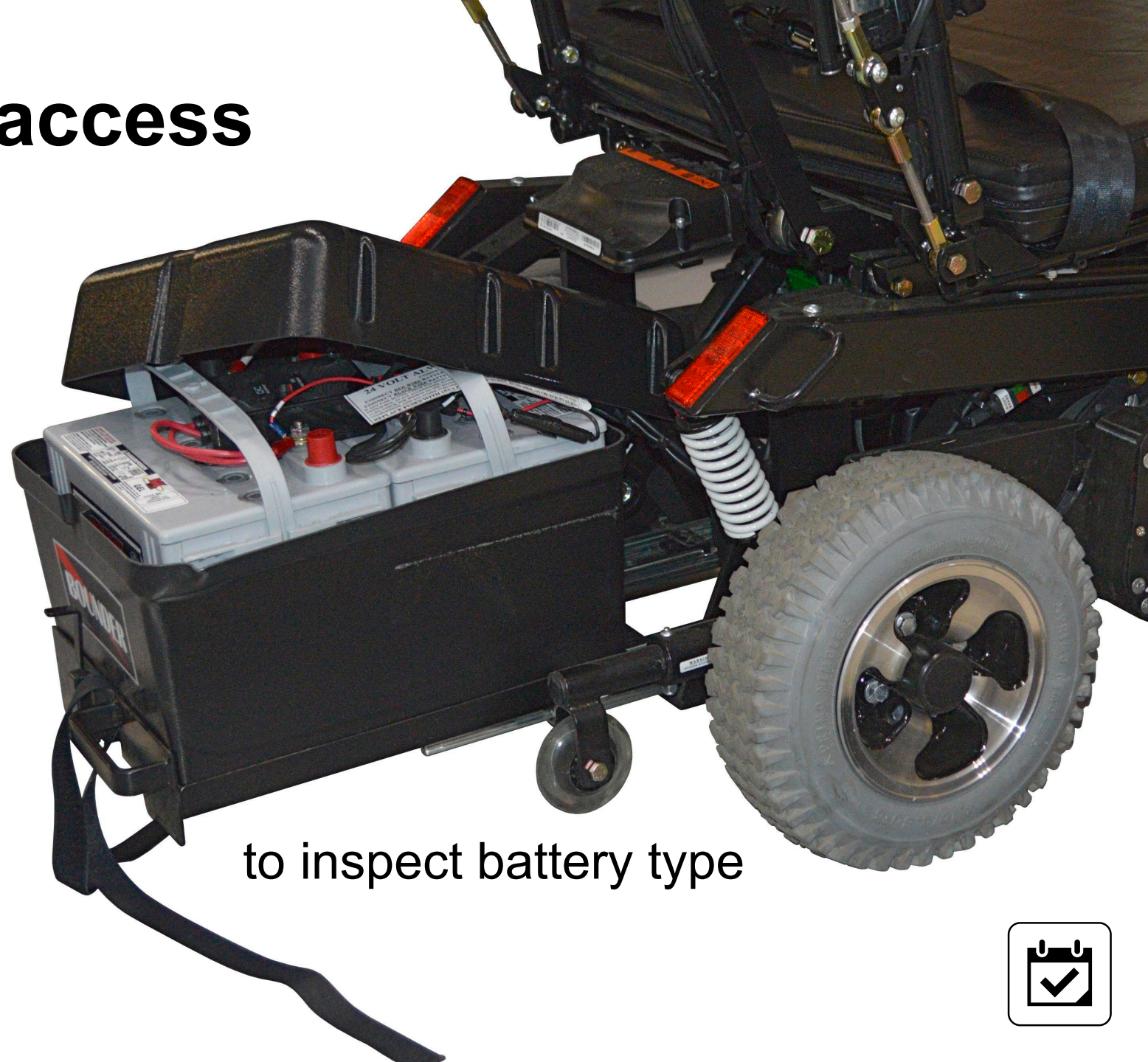

to inspect battery type



# Review aircraft Access information

Make and model, cargo door height and width

<https://wheelchairtravel.org/air-travel-airplane-cargo-hold-dimensions/>

## Future information

Cargo hold door height (33 in. min)

Cargo hold ceiling height

Priority stowage area dimensions

Overhead bin dimensions (22 x 14 x 9)

Aisle width from the floor up 18 typical

Lavatory information and dimensions





**Aircraft cargo door heights vary greatly**



# Mobility device air travel information

Personal Decision

Under which circumstances may the mobility device lay on its side?

Which side of the mobility device may contact  
the ground or floor surface?

Travel in manual WC

Travel in portable PWC

Prepare WC for Air Travel





# Preparation



## Preparation for the trip

# Personal hygiene checklist

### Toileting

Seat or cushion

Gloves

Zip-locks

Wet wipes

Chux

### Bathing

Cushion

Soap

Shampoo

Shower chair

### Grooming

Shave

Teeth

Skin care

Mirror

Creams

### Medications

Normal

Emergency

Bandages



## Preparation for the trip

# Personal items checklist

### Clothing

Socks

Shorts

Pants

Shirts

Tie

Vest

Jacket

Rain coat

Hat

Gloves

### Food

Ice pack

Fruit

French toast

Lunch meat

Cheese

Apple

Nuts

Zip-locks

Peanut butter cups

### Personal

Wallet

ID

Passport (if international)

Phone

Phone charger

Vehicle keys

House keys



# Preparation for the trip

## Work checklist

### Work

Laptop

iPad

Chargers

Documents

USB drive

Headset

Headphones

Reading material

Business cards



## Preparation for the trip

# Mobility device checklist

### Wheelchair

Travel wheels

Second cushion

Spare tube

Plastic tire irons

Pump

Spare caster

Air in tires

### Air travel

Bag for removable components

Air travel configuration card

Air travel labels

Strap to hold WC folded



# Preparation for the trip

## Specialty checklist

### Ski trip

Skis in ski bag

Mono-ski wrapped

Gel cushion

Shin guards

Fleece layers

Boots fleece liners

Hand warmers

Helmet goggles

Skit pass / holder

Jacket

Extra layers

### Aviating

iPads with nav maps

Flight clipboard Wx

Current Garmin data

Order fuel

Check Wx and TFRs

File flight plan

Brief passengers



# Preparation for the trip

## Travel checklist

### Leaving

Gas in vehicle

Prepare vehicle

Pack vehicle

Adjust thermostat

Lock doors

Set lights

### Airport

Neck pouch

ID

Passport

Money

Boarding info

### Flight

Extra cushion

Inflatable lumbar support

Backpack for foot support

Noise cancelling earplugs/headphones

Extra clothing layers for warmth



# Thinking ahead about **Where you will need to sit**

Boarding device

Aircraft seating

Consider carrying  
secondary cushion



# Boarding devices seating pressures

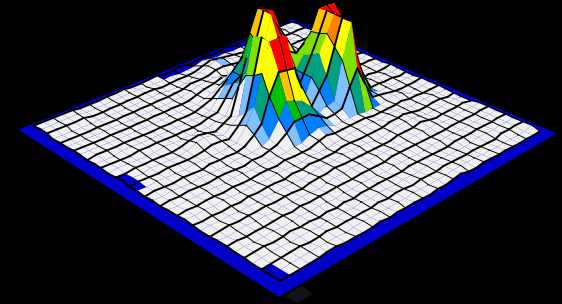
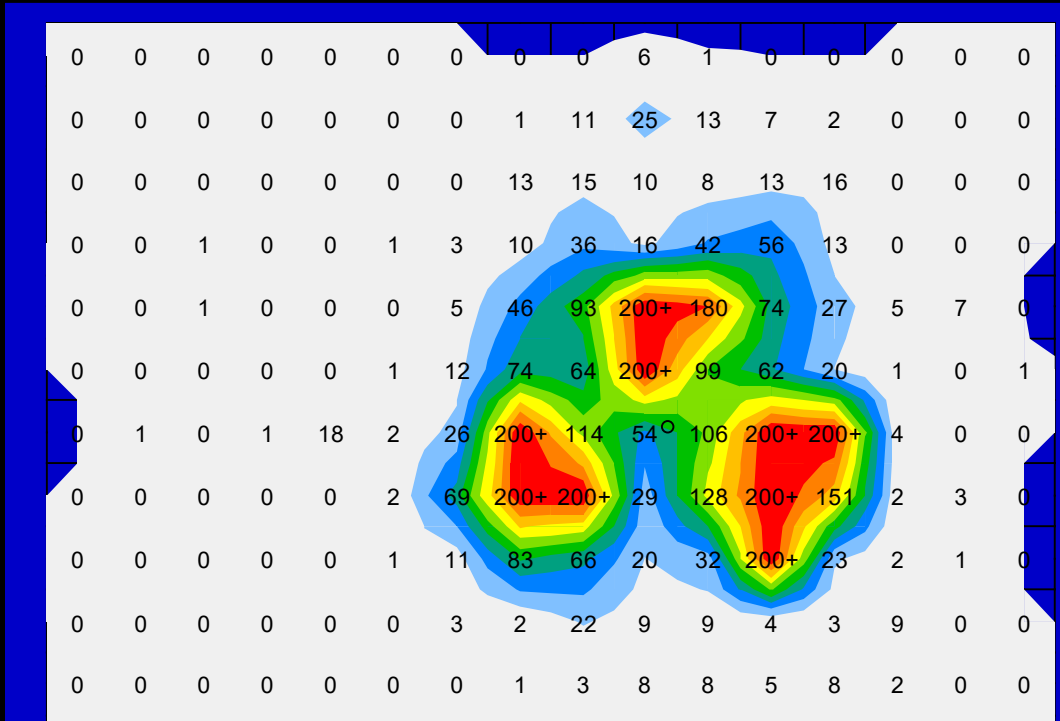

Consider carrying a secondary cushion



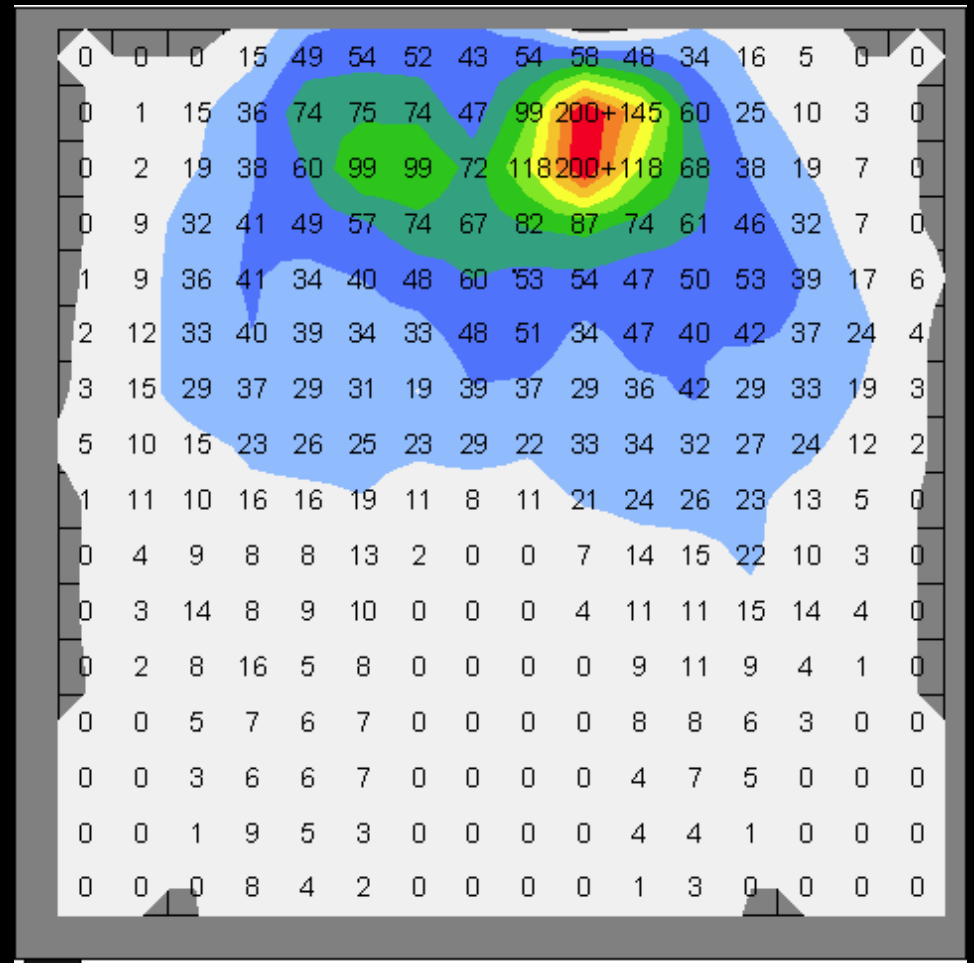
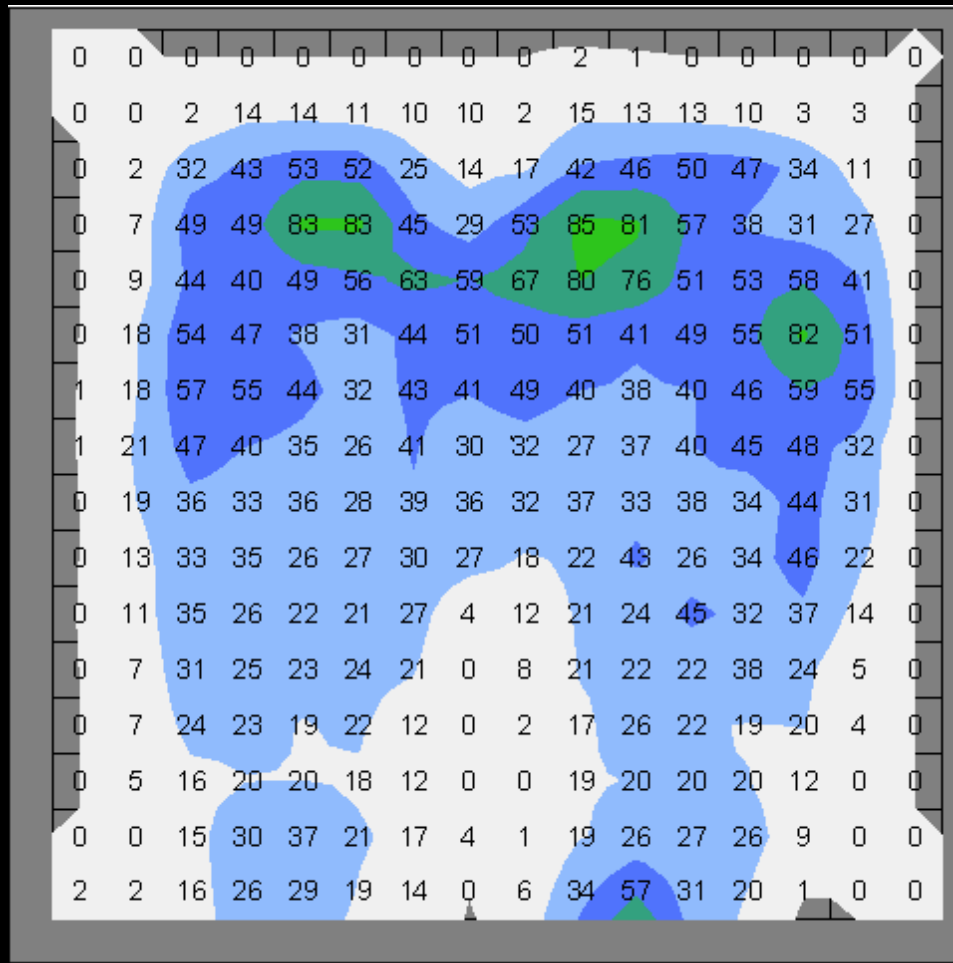

# Aircraft seating with pressure relief from... **Wheelchair cushion**

Legs hanging

Shoulders forward

Neck extended

Arms not supported

Not comfortable

Legs swell due to  
poor circulation



Aircraft seating with pressure relief from...

# Wheelchair cushion and accessories

Foot support

Inflatable lumbar  
and spine support

Inflatable neck  
and head support

Arm support



# Aircraft seating with pressure relief

## Ready to fly

Foot support

Lumbar and spine support

Neck/head support

Arm support





# Mobility device preparation

## Air travel configuration card

### Communicating essential information

to air carrier staff  
for handling the  
mobility device





**Highly recommended**  
for existing powered  
mobility devices

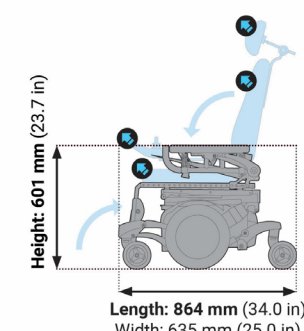
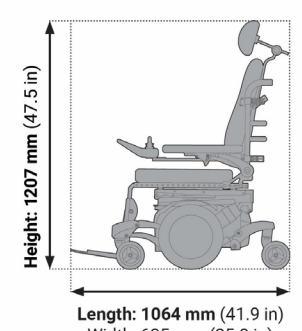

**air travel information** 

Manufacturer Model   
COMPLIANT with RESNA AT-1

owner: John Doe    phone: ### ### ####    email: john.doe@email.com    chair serial number: 720003

air travel preparation	air travel configuration	driving configuration
<p>The owner of this device, or a designated assistant, is encouraged to participate in the following process.</p> <ol style="list-style-type: none"><li><b>remove seat cushion</b> Remove seat cushion; store in aircraft cabin.</li><li><b>remove head support</b> Remove head support; store in aircraft cabin.</li><li><b>lower back support to fit into aircraft</b> Remove back support cushion; store in aircraft cabin. Cushion is fixed in place by means of velcro on the rear. Disconnect quick release pin on back support actuator at the attachment point behind back support. Fold back support forward.</li><li><b>remove joystick</b> Remove electrical connection to joystick. Remove joystick controller; store in aircraft cabin.</li><li><b>raise foot supports</b> Move foot supports to upright position.</li><li><b>isolate battery power</b> Switch breaker to off to fully disconnect power.</li><li><b>disengage drive system</b> Rotate lever on each motor to manually push the mobility device.</li></ol>	 <p>Height: 601 mm (23.7 in) Length: 864 mm (34.0 in) Width: 635 mm (25.0 in)</p>	 <p>Height: 1207 mm (47.5 in) Length: 1064 mm (41.9 in) Width: 635 mm (25.0 in)</p>
	<p><b>unoccupied product weight</b>  <b>150 kg (330 lb)</b> <b>WARNING:</b> This product should be lifted using a mechanical lift to avoid injury.</p>	<p><b>battery information</b>  <b>WARNING:</b> Only non-spillable lead acid group 34 batteries may be installed on this product. This wheelchair was manufactured with <b>2 lead acid sealed gel cell non-spillable batteries</b> conforming to DOT 49 CFR 173.159 (d) and IATA Provision A67.</p>
	<p><b>weight of additional components</b> (if greater than 10 kg)  _____ kg    _____ lb</p>	

rev: 2024-08-06



owner: John Doe





phone: ### ### ####

email: john.doe@email.com

chair serial number: 720003

## air travel preparation

The owner of this device, or a designated assistant, is encouraged to participate in the following process.

-  **remove seat cushion**  
Remove seat cushion; store in aircraft cabin.
-  **remove head support**  
Remove head support; store in aircraft cabin.
- lower back support to fit into aircraft**  
Remove back support cushion; store in aircraft cabin. Cushion is fixed in place by means of velcro on the rear. Disconnect quick release pin on back support actuator at the attachment point behind back support. Fold back support forward.
-  **remove joystick**  
Remove electrical connection to joystick.  
Remove joystick controller; store in aircraft cabin.
- raise foot supports**  
Move foot supports to upright position.
-  **isolate battery power**  
Switch breaker to off to fully disconnect power.
-  **disengage drive system**  
Rotate lever on each motor to manually push the mobility device.

## air travel configuration

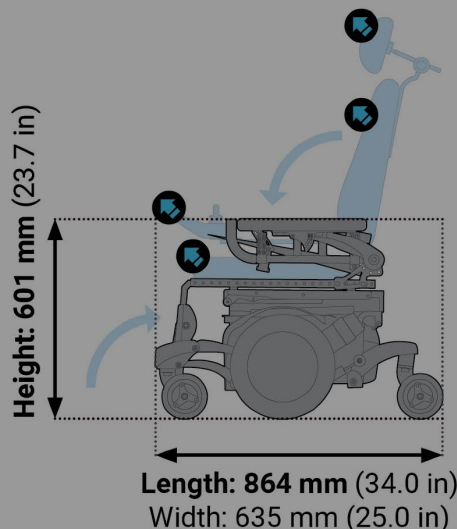

## driving configuration

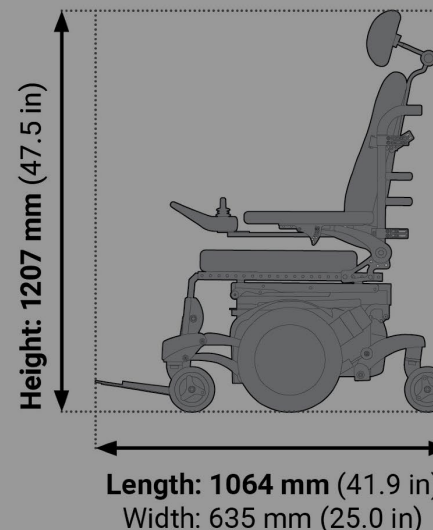

### unoccupied product weight

**150 kg (330 lb)**

**WARNING:** This product should be lifted using a mechanical lift to avoid injury.



### weight of additional components (if greater than 10 kg)

\_\_\_\_\_ kg \_\_\_\_\_ lb



### battery information

**WARNING:** Only non-spillable lead acid group 34 batteries may be installed on this product.

This wheelchair was manufactured with **2 lead acid sealed gel cell non-spillable batteries** conforming to DOT 49 CFR 173.159 (d) and IATA Provision A67.





owner: John Doe







phone: ### ### ####

email: john.doe@email.com

chair serial number: 720003

## air travel preparation

The owner of this device, or a designated assistant, is encouraged to participate in the following process.

-  **remove seat cushion**  
Remove seat cushion; store in aircraft cabin.
-  **remove head support**  
Remove head support; store in aircraft cabin.
-  **lower back support to fit into aircraft**  
Remove back support cushion; store in aircraft cabin. Cushion is fixed in place by means of velcro on the rear. Disconnect quick release pin on back support actuator at the attachment point behind back support. Fold back support forward.
-  **remove joystick**  
Remove electrical connection to joystick.  
Remove joystick controller; store in aircraft cabin.
-  **raise foot supports**  
Move foot supports to upright position.
-  **isolate battery power**  
Switch breaker to off to fully disconnect power.
-  **disengage drive system**  
Rotate lever on each motor to manually push the mobility device.

## air travel configuration

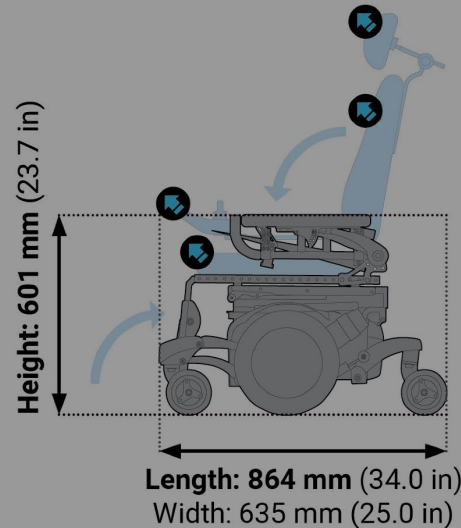

## driving configuration

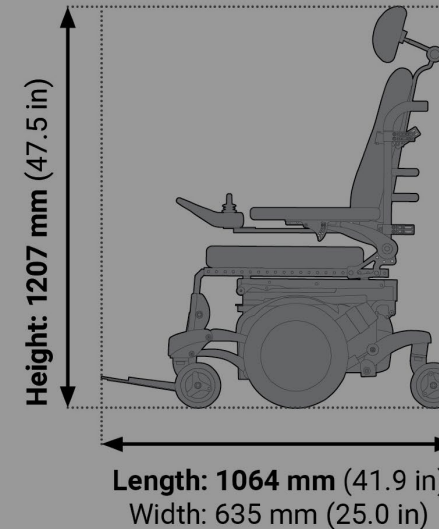

**unoccupied product weight**  
**150 kg (330 lb)**

**WARNING:** This product should be lifted using a mechanical lift to avoid injury.



**weight of additional components**  
(if greater than 10 kg)

\_\_\_\_\_ kg \_\_\_\_\_ lb



### battery information

**WARNING:** Only non-spillable lead acid group 34 batteries may be installed on this product.

This wheelchair was manufactured with **2 lead acid sealed gel cell non-spillable batteries** conforming to DOT 49 CFR 173.159 (d) and IATA Provision A67.





owner: John Doe

phone: ### ### ####

email: john.doe@email.com

chair serial number: 720003

## air travel preparation

The owner of this device, or a designated assistant, is encouraged to participate in the following process.

- remove seat cushion**  
Remove seat cushion; store in aircraft cabin.
- remove head support**  
Remove head support; store in aircraft cabin.
- lower back support to fit into aircraft**  
Remove back support cushion; store in aircraft cabin. Cushion is fixed in place by means of velcro on the rear. Disconnect quick release pin on back support actuator at the attachment point behind back support. Fold back support forward.
- remove joystick**  
Remove electrical connection to joystick.  
Remove joystick controller; store in aircraft cabin.
- raise foot supports**  
Move foot supports to upright position.
- isolate battery power**  
Switch breaker to off to fully disconnect power.
- disengage drive system**  
Rotate lever on each motor to manually push the mobility device.

## air travel configuration

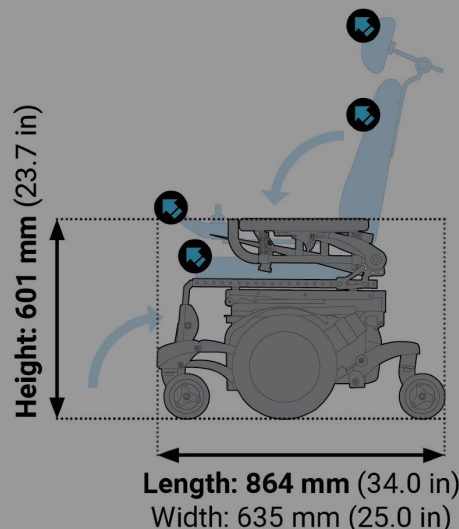

## driving configuration

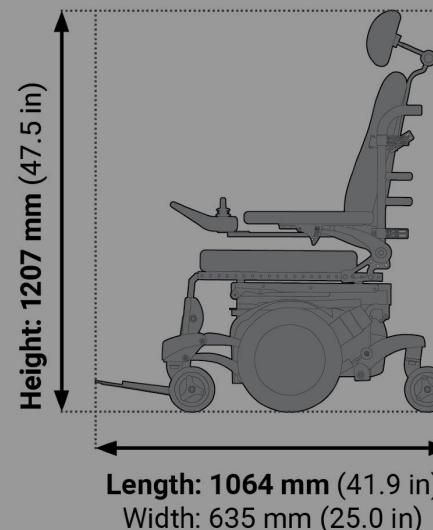

### unoccupied product weight

**150 kg (330 lb)**

**WARNING:** This product should be lifted using a mechanical lift to avoid injury.



### weight of additional components (if greater than 10 kg)

\_\_\_\_\_ kg \_\_\_\_\_ lb



### battery information

**WARNING:** Only non-spillable lead acid group 34 batteries may be installed on this product.

This wheelchair was manufactured with **2 lead acid sealed gel cell non-spillable batteries** conforming to DOT 49 CFR 173.159 (d) and IATA Provision A67.





owner: John Doe

phone: ### ### ####

email: john.doe@email.com

chair serial number: 720003

## air travel preparation

The owner of this device, or a designated assistant, is encouraged to participate in the following process.

- remove seat cushion**  
Remove seat cushion; store in aircraft cabin.
- remove head support**  
Remove head support; store in aircraft cabin.
- lower back support to fit into aircraft**  
Remove back support cushion; store in aircraft cabin. Cushion is fixed in place by means of velcro on the rear. Disconnect quick release pin on back support actuator at the attachment point behind back support. Fold back support forward.
- remove joystick**  
Remove electrical connection to joystick.  
Remove joystick controller; store in aircraft cabin.
- raise foot supports**  
Move foot supports to upright position.
- isolate battery power**  
Switch breaker to off to fully disconnect power.
- disengage drive system**  
Rotate lever on each motor to manually push the mobility device.

## air travel configuration

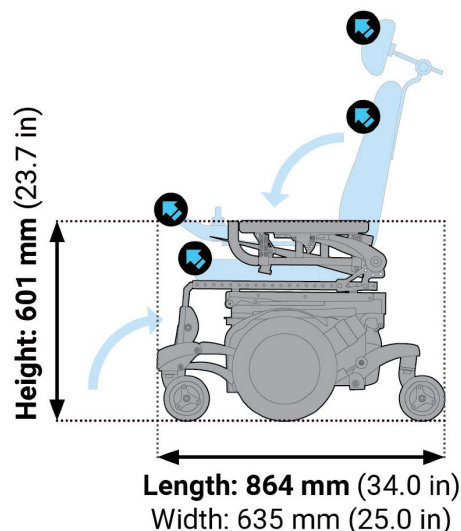

## driving configuration

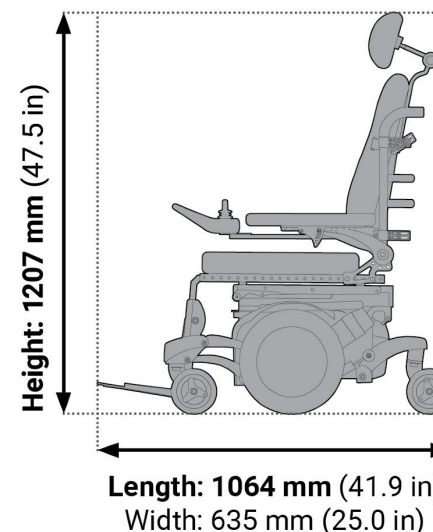

### unoccupied product weight

**150 kg (330 lb)**

**WARNING:** This product should be lifted using a mechanical lift to avoid injury.



### weight of additional components (if greater than 10 kg)

\_\_\_\_\_ kg \_\_\_\_\_ lb



### battery information

**WARNING:** Only non-spillable lead acid group 34 batteries may be installed on this product.

This wheelchair was manufactured with **2 lead acid sealed gel cell non-spillable batteries** conforming to DOT 49 CFR 173.159 (d) and IATA Provision A67.



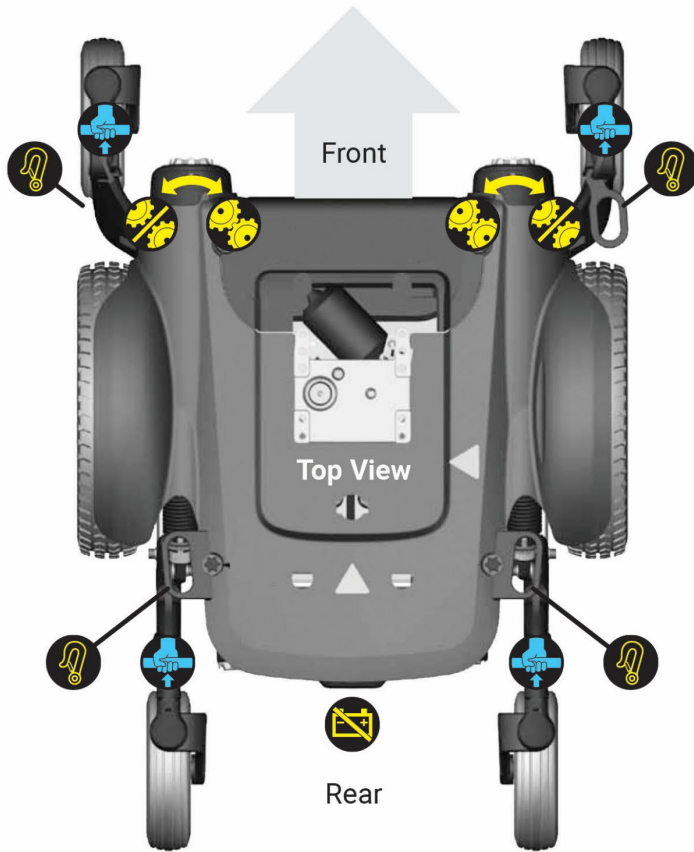
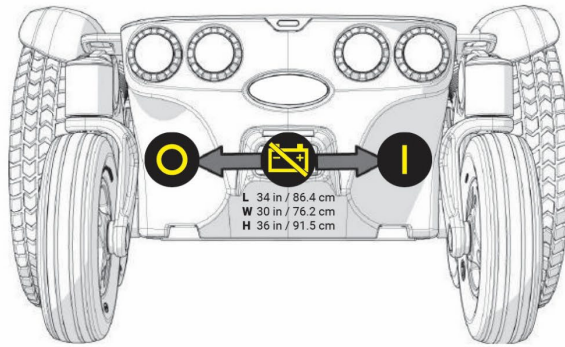

### isolate battery power SWITCH

Switch breaker to off to disconnect power from the battery.  
The circuit breaker is located in the rear beneath the tail lights.



### disengage drive system

Move levers outwards to release the brakes.  
Disengage drive motors with brake release levers to move product manually. The brake release levers are located at the front of the mobility device.



### manual lift points

Manual lift points are located on all four caster arms.  
**WARNING!** This product should be lifted using a mechanical lift to avoid injury. Unoccupied product weight is 150 kg (330 lb).



### chair securement

RESNA WC19 securement points can be used to secure the mobility device.  
After positioning and securing the mobility device, re-engage the drive system to lock the drive wheels.



### operator's manual online

Scan the QR code to download the Make Model operator's manual.  
Please [URL](#) for more information.

14 CFR §382.129(a) states the following:

"As a carrier, you must permit passengers with a disability to provide written directions concerning the disassembly and reassembly of their wheelchairs, other mobility aids, and other assistive devices. **You must carry out these instructions to the greatest extent feasible...**"



# Air Travel Configuration Card

Scan QR code for samples

<https://www.beneficialdesigns.com/air-travel/air-travel-configuration-card/>



# Review departure, connecting and arrival Airport information via internet

Location of accessible parking

Terminal map – arrival and departure gates

Read about the airport ...”getting around the Denver  
Airport”

Request assistance if needed

Bathroom and eating locations

Baggage location



# Flight preparation

**Pay** for TSA Pre check and checked luggage in advance

**Check in** 24 hours ahead

**Print** boarding information or save on phone

**Review** parking map and determine time necessary

**Determine** assistance needed for luggage:

Get a ride from someone

Ride the shuttle

Go back and forth from car

Get a porter from baggage claim

Arrange assistance with contracted air travel service providers

Get baggage staff to help



СОКОЛОВО



# Airport Arrival and Parking



# Accessible parking

Sometimes not available

Look for a large space and request assistance when you return

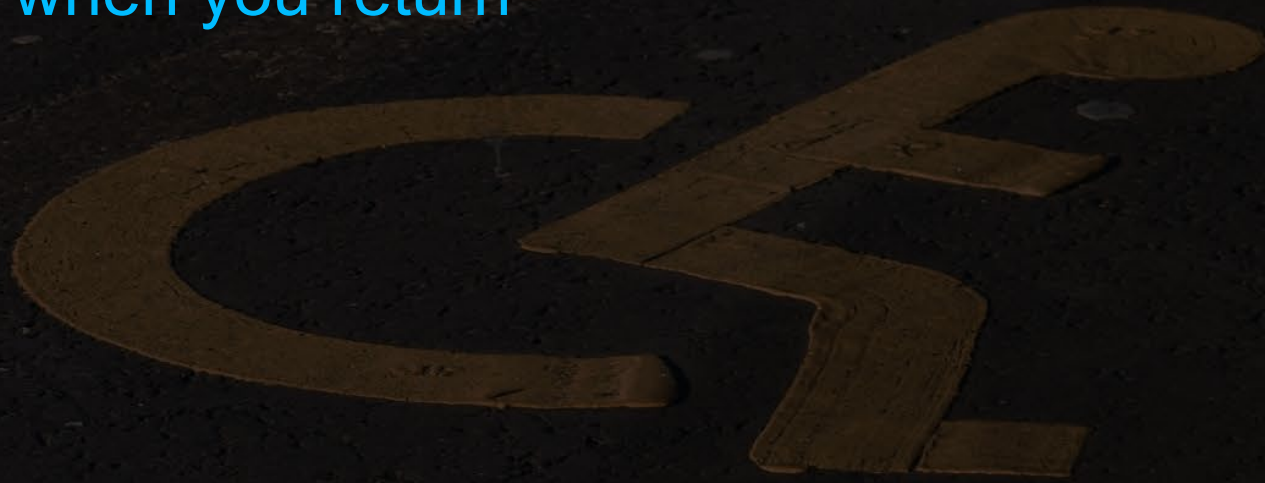

# Construction

Construction can make it impossible to check luggage curbside

Park and go inside to request assistance

Arrange for assistance in advance

Porter from the baggage area

Air Travel Service Provider

Air carrier agent



# Curbside baggage check-in

Option to check baggage at the curb

Visit ticket counter to confirm everything

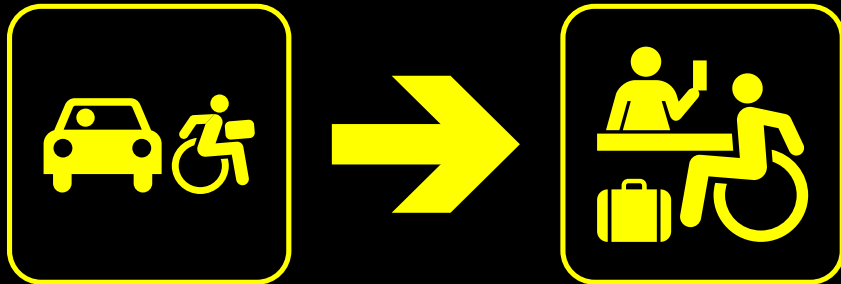



# Ticket Counter



# Ticket counter Check in

## Mobility device...

Use your personal wheelchair to go through security to gate

Gate dispatch tag

No charge for traveling with AT

Consider checking your mobility device at the ticket counter if this is an option for you

## Baggage



Ticket counter

# Mobility device delivery

Regardless of where checking it...

If stowing mobility device in cargo hold...

where should your mobility device be **delivered** to you?

Connecting airport passenger boarding bridge

Destination airport passenger boarding bridge

Destination airport baggage claim



# Ticket counter

## Verify...

Flight delays or change in aircraft

Mobility device air travel information—starting with weight

Seating location

Assistance needed through security and to gate

Meeting with ramp agent to review mobility device

Communicate that mobility device has **non-spillable batteries**



## Ticket counter

# Request assistance if desired

Going through security – can speed things up

Getting through airport

Boarding transfers using boarding devices

Deplaning transfers using boarding devices

Assistance needed at connecting airport

Assistance needed at destination airport



# Leaving ticket counter

In preparation for security...

**make sure you have secure and accessible:**

Personal ID

Boarding pass

Claim check

Carry-on baggage

Request a plastic bag for removal of MD accessories





Security



## Security checkpoint

# Assistance available

**Consider applying for Pre-check – a paid service**

No full-body pat down required

**Contracted air travel service provider escort**

Typically eliminates the normal wait in line

**Private screening**

Be ready to state you are unable to remove your shoes and would like a private screening with a caregiver if desired



## Security checkpoint

# Using bins to scan personal items

**Request** bins and **explain** WC users have more items

Carry-on, with emergency overnight medical supplies

Food and medications needed

Medical liquids

Computer/tablets

Bag for accessories

Aircraft seating modifications

Spare cushion



## Security checkpoint

# Consider use of a chest or neck pouch

Boarding pass and ID need to be **easily accessible**  
and **safe** on your person at all times

Leave hands free





# Departure Gate

Departure gate

# Check in at gate

**Communicate** your limitations

If you visited the ticket counter...

Review information verified at ticket counter

If you did **not** visit the ticket counter...

Verify all information specified for ticket counter verification



Departure gate

# Gate information

## Determine

**When** to meet with ramp agent if using powered WC

**What** boarding device is available and necessary

**When** to arrive back at the departure gate

**When** to pre-board

Manual wheelchair user may request storage of WC  
**onboard the aircraft** per ACAA

If problems, request the complaint resolution officer (CRO)





# Ramp Agent Meeting

# Powered wheelchair users should **Request to meet with ramp agent**

**Provide mobility device air travel information**

**Review air travel preparation steps**

- 1 Reduce** the height of your mobility device
- 2 Remove** components
- 3 Isolate** battery power
- 4 Disengage** drive system at gate or in the jetway





Transfer  
from Wheelchair



# Transfers

**Transferring between mobility device,  
boarding device, and aircraft seat...**

Can you independently transfer?

What assistance do you need?

Is a mechanical transfer lift available?

Can air travel service providers assist you?







boarding bridge

uphill

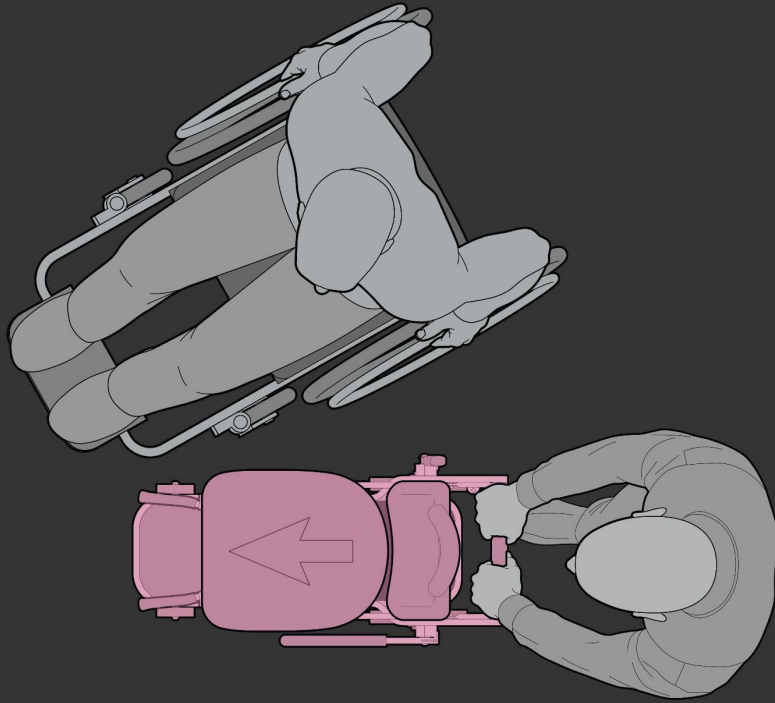

downhill

aircraft door









boarding bridge

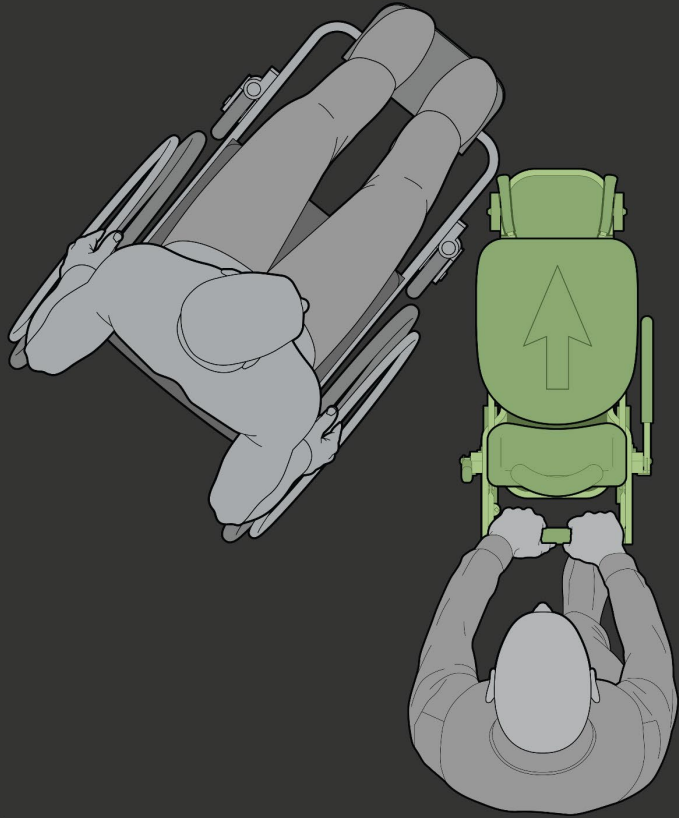

downhill



aircraft door





# Wheelchair Preparation to Fly



To hold a wheelchair in a folded position...

## Use a strap or latch mechanism

To prevent damage

and...

To make the  
wheelchair easier  
to handle





# Mobility device preparation

Be familiar with air travel preparation steps:

- 1 Know how to **reduce the height** of your mobility device
- 2 Plan which **components to remove** and know how
- 3 Know how to **isolate batteries** using either a switch or plug
- 4 Know how to **disengage** the drive system



# Air travel preparation

## Height comparison

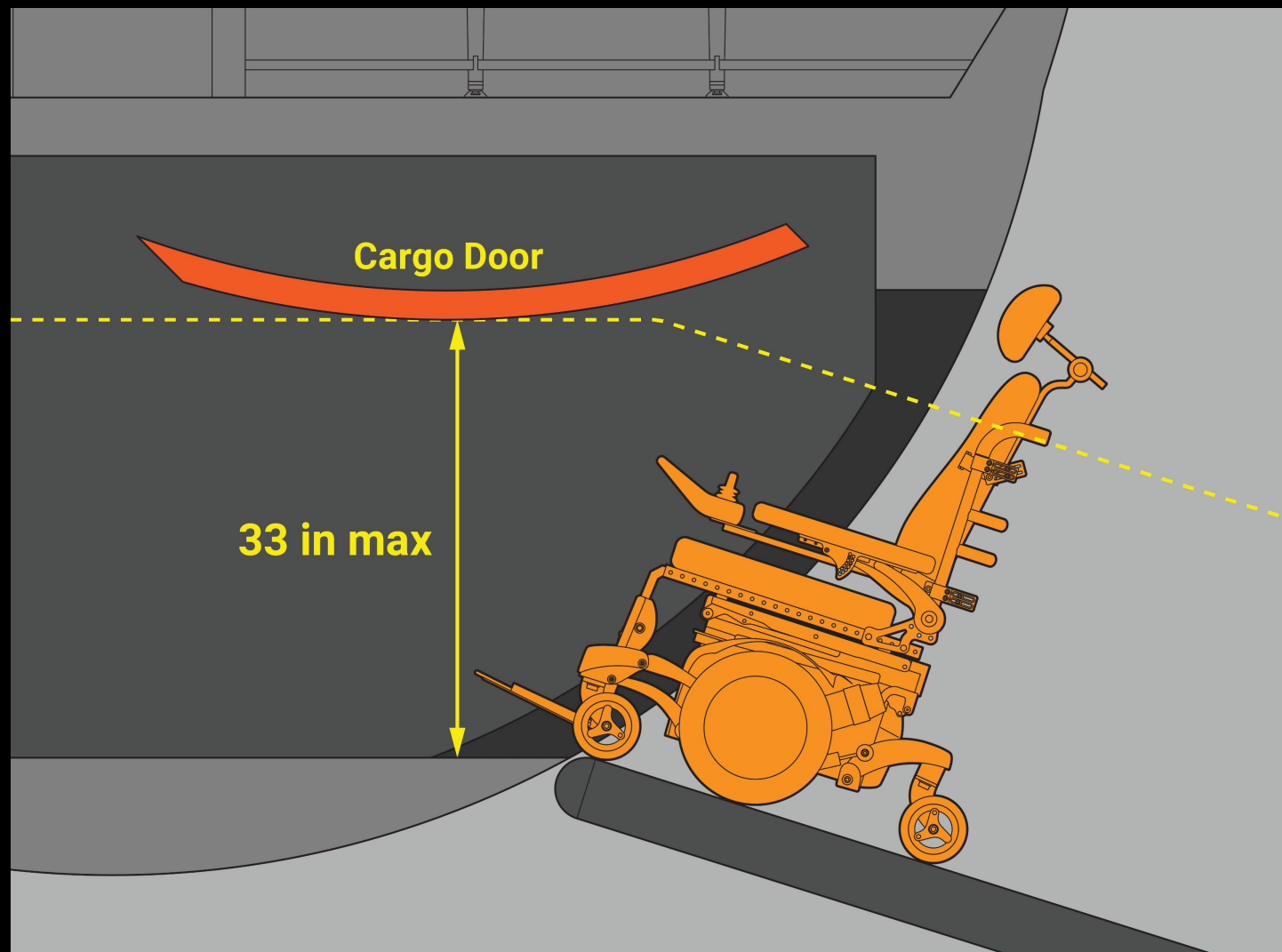

## Air travel preparation

# 1 Reduce the height

PMDs meeting the RESNA AT-1  
Sec 4 Standard must have an  
**air travel configuration with  
reduced height – 33 in**



# Air travel preparation

## Air travel configuration

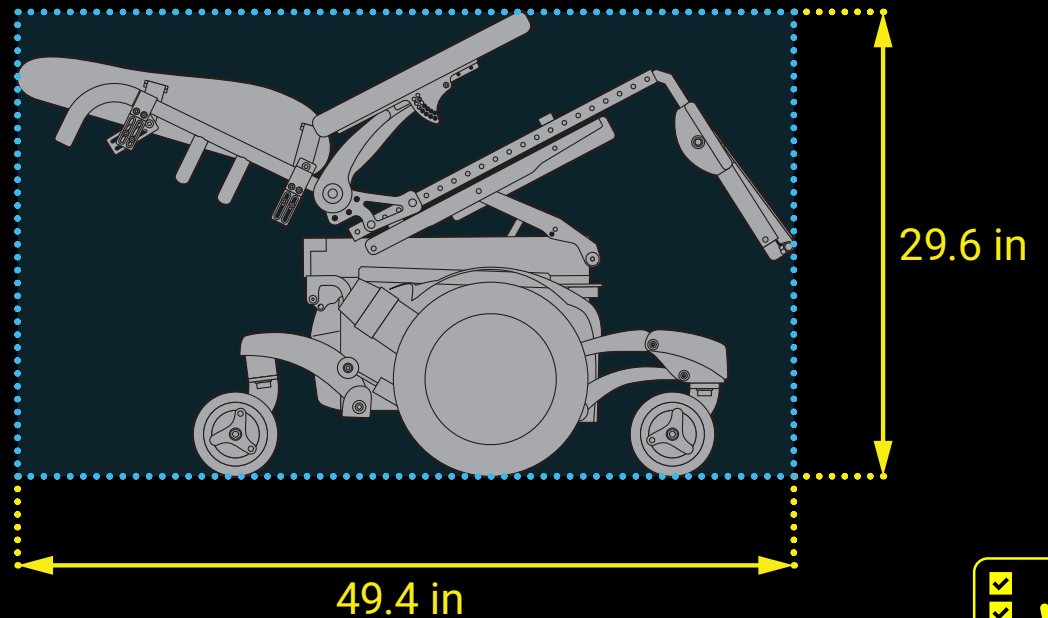
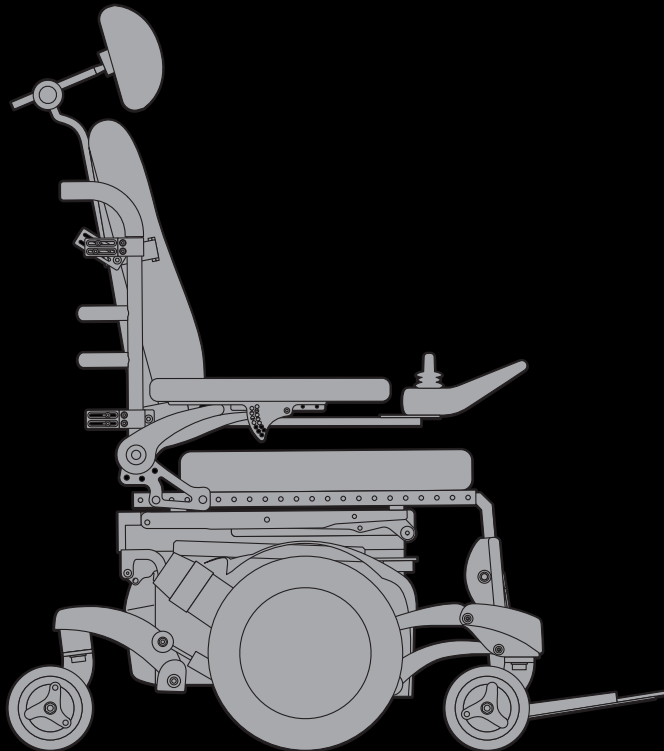

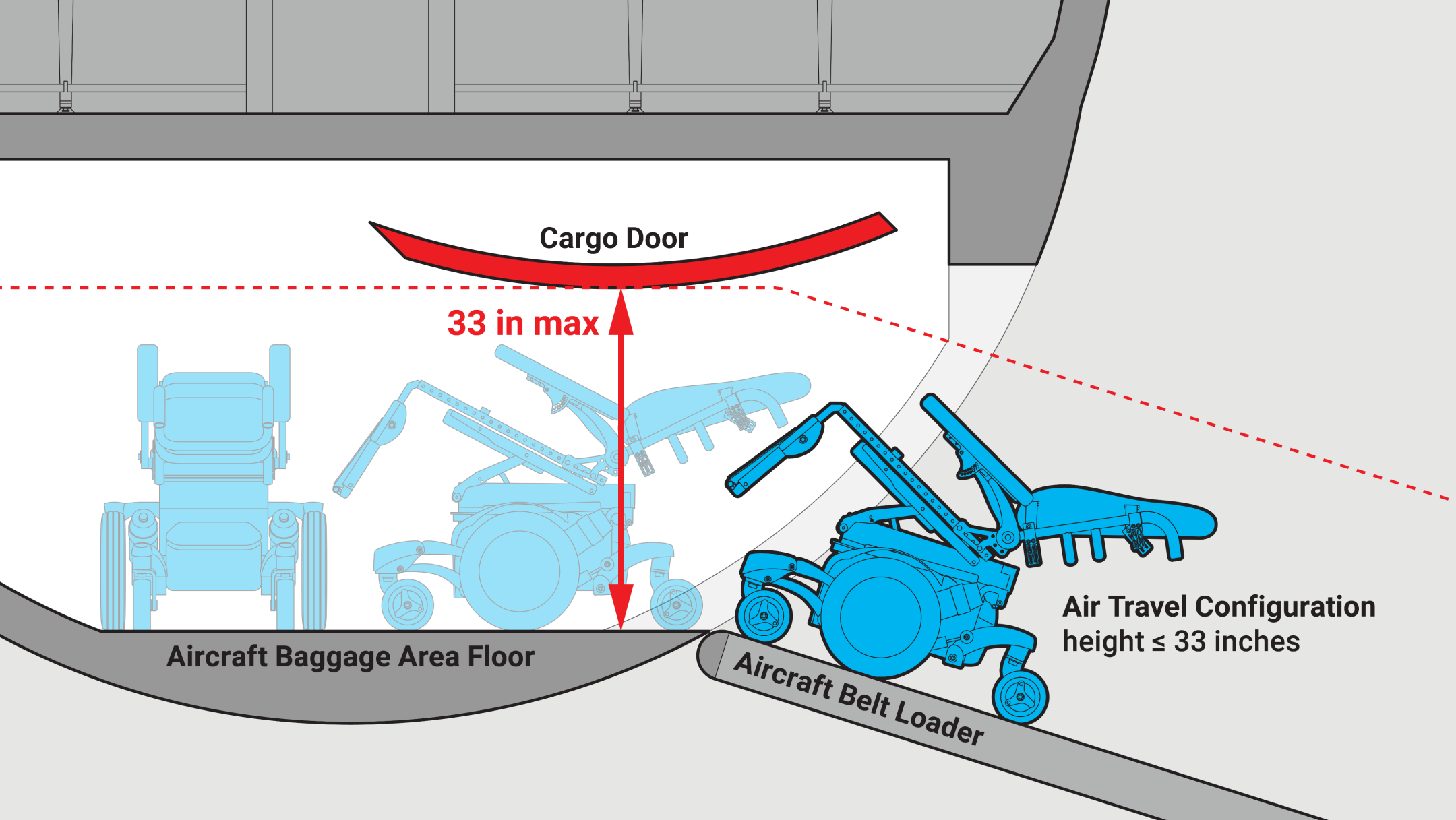

Cargo Door

33 in max

Aircraft Baggage Area Floor

Aircraft Belt Loader

Air Travel Configuration  
height  $\leq$  33 inches



## Air travel preparation

# Fitting through the cargo door

Will the mobility device fit through the cargo door while positioned upright?

**33 in maximum**  
height in many aircraft



## Air travel preparation

# 2 Remove components

Store components inside the aircraft that could otherwise be lost or damaged

Other components that could be lost or damaged during air travel should be removed and stowed in a travel bag inside the aircraft cabin

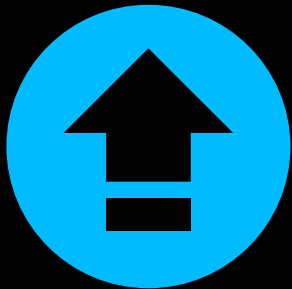

# Latch mechanisms

Removable components should be stored in the aircraft cabin



Invacare AVIVA STORM RX **Powered Wheelchair**  
<https://pro.invacare.com/Mobility/Powered-Wheelchairs/Rear-Wheel-Drive/Invacare-AVIVA-STORM-RX-Power-Wheelchair---Ultra-Low-Maxx-Multi-Actuator-Power-Positioning-System/p/SRX-20MP>





RESNA AT-1 requires accessories to remove without tools...

**Until such chairs exist...**

**Consider use of tools to remove accessories that might otherwise be damaged or lost**



RESNA AT-1 requires the joystick to be removable...

**If joystick is not removable...**

**Consider protecting the joystick**



RESNA AT-1 requires the joystick to be removable...

**If joystick is not removable...**

**Consider protecting the  
control input device**



## Air travel preparation

# 3 Isolate battery power

Disconnect the battery power using the switch on a PMD meeting the RESNA AT-1 standard

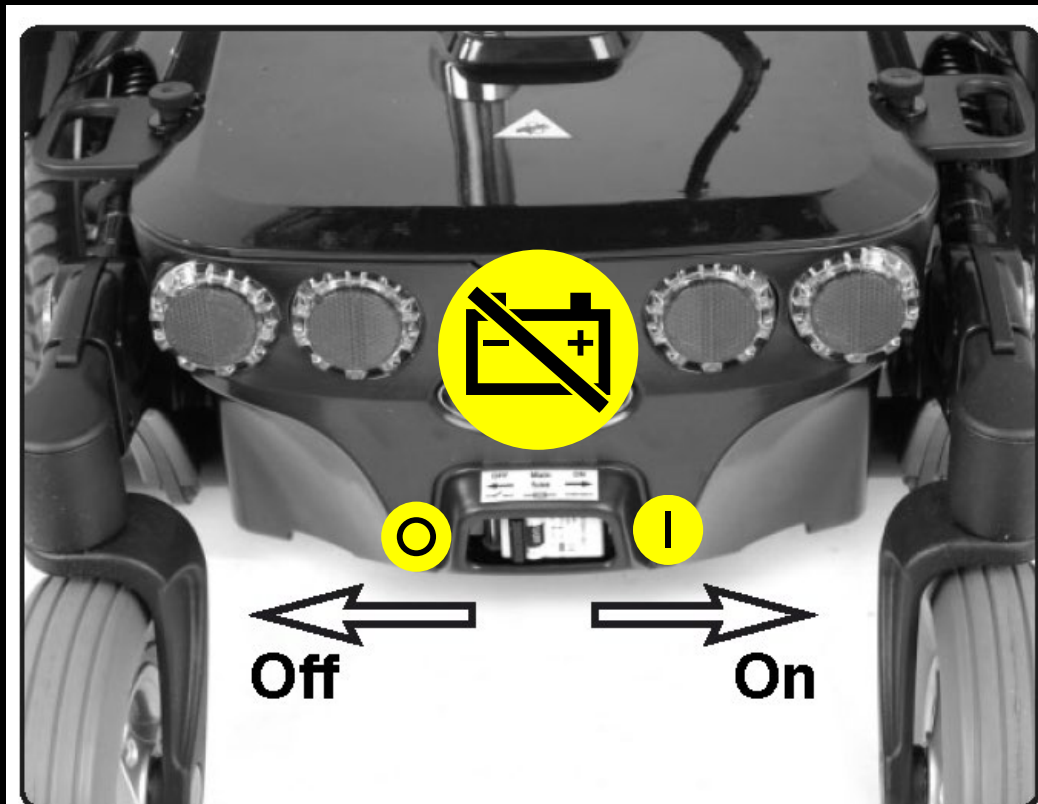

RESNA AT-1 requires a battery isolation switch...

**If no battery isolation switch exists...**

**Separate the power connection**



## Air travel preparation

# 4 Disengage the drive system

Disengage the drive system to enable the mobility device to be manually pushed



R

N

M-D





SUNRISE  
MEDICAL

Part No. 20021  
Type: DC 22.0V  
Motor: DC 22.0V  
Gear Ratio: 28.6:1  
Power: 280W  
Rev. F



DWR1235L798 REV C

The label features five icons in a vertical sequence: 1. A yellow circle containing two interlocking black gears. 2. A red circle with a diagonal slash over a black silhouette of a person riding a lawnmower. 3. A black triangle with a white exclamation mark inside. 4. A red circle with a diagonal slash over a black silhouette of a person mowing. 5. A yellow circle containing two interlocking black gears with a diagonal slash over them.





# Wheelchair's Journey into Aircraft

# Storage of wheelchair in aircraft

## From jetway to cargo hold

The path your mobility device takes to get to the cargo hold

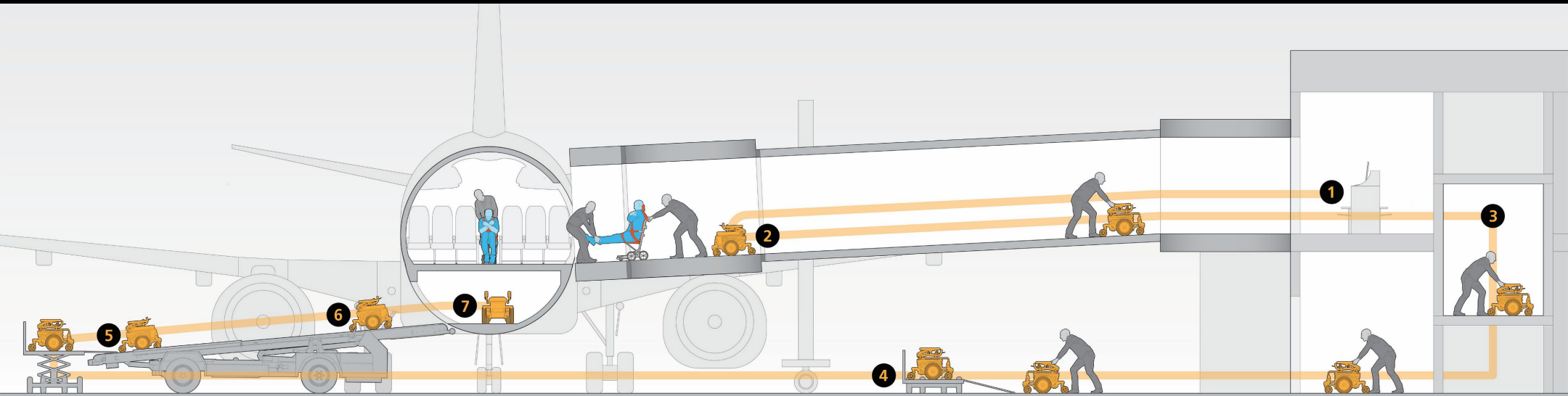

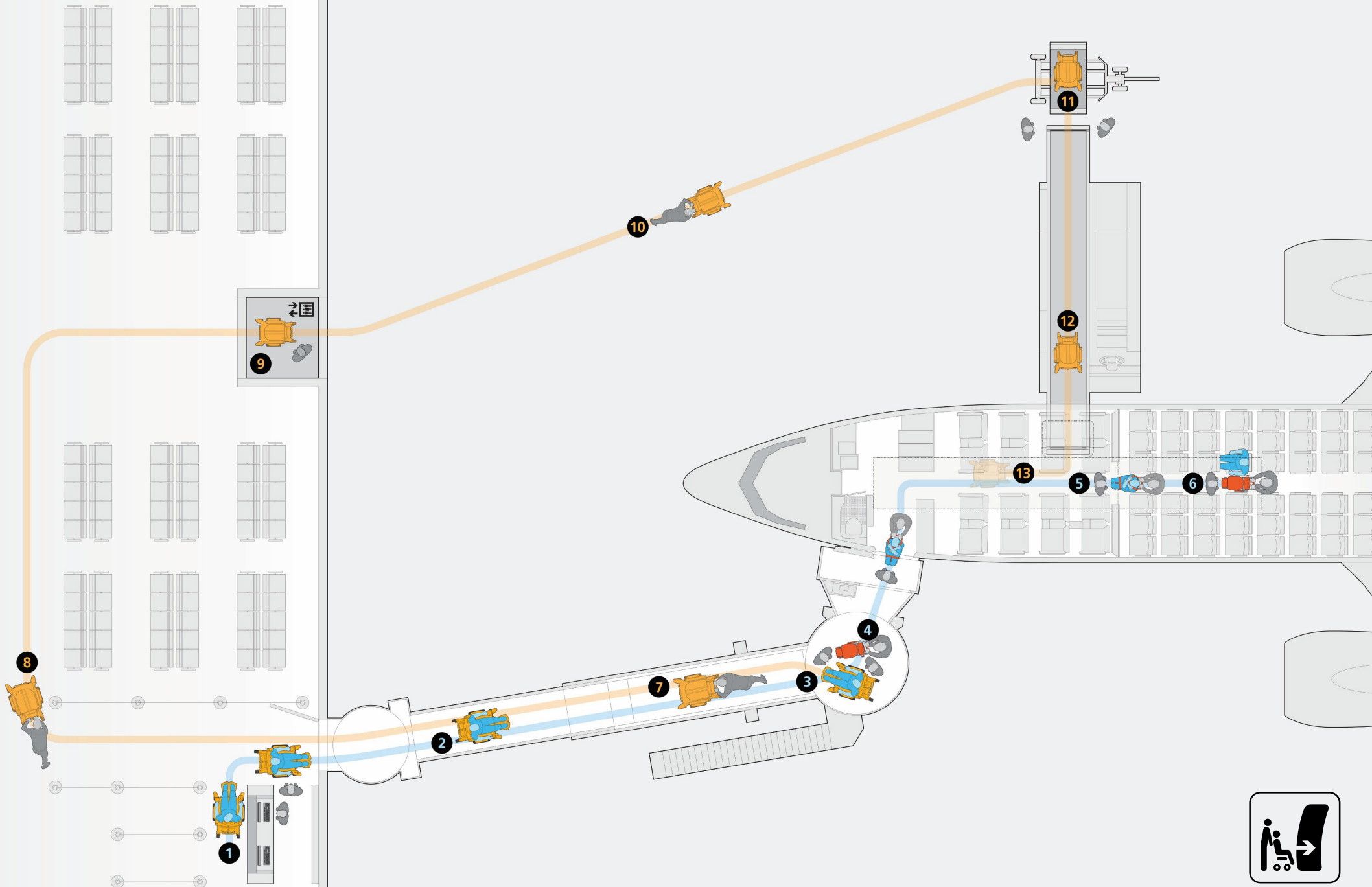

# Storage of wheelchair in aircraft

## Transfer between tarmac & cargo hold







**WheelchairTravel.org**

<https://wheelchairtravel.org/air-travel/airplane-cargo-hold-dimensions/faq-air-airplane-cargo-hold-dimensions-wheelchair-belt-loader/>





# Storage of wheelchair in aircraft

## Securement of mobility device

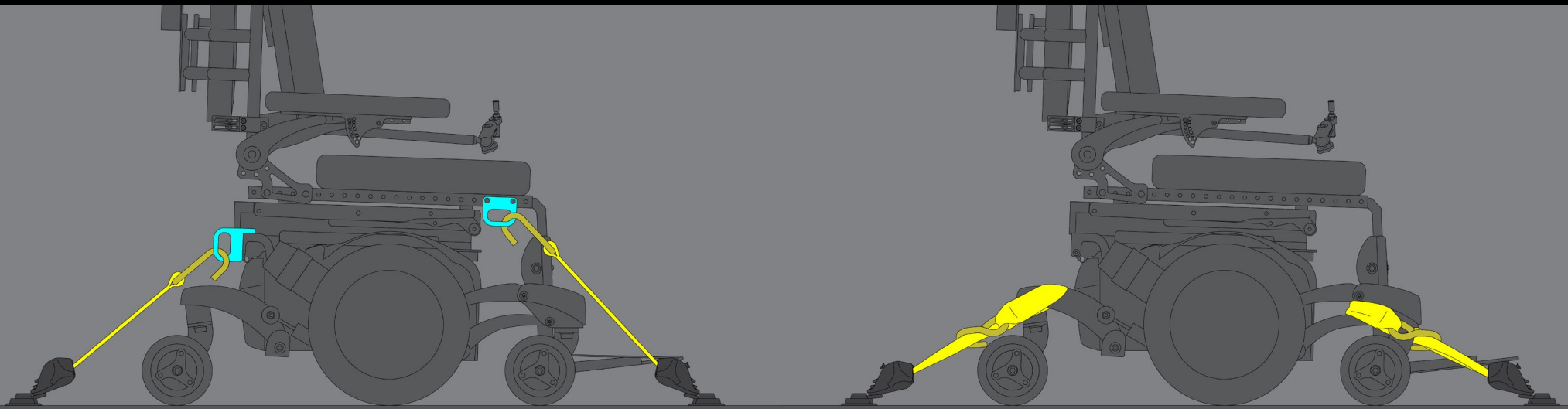



# Passenger Boarding





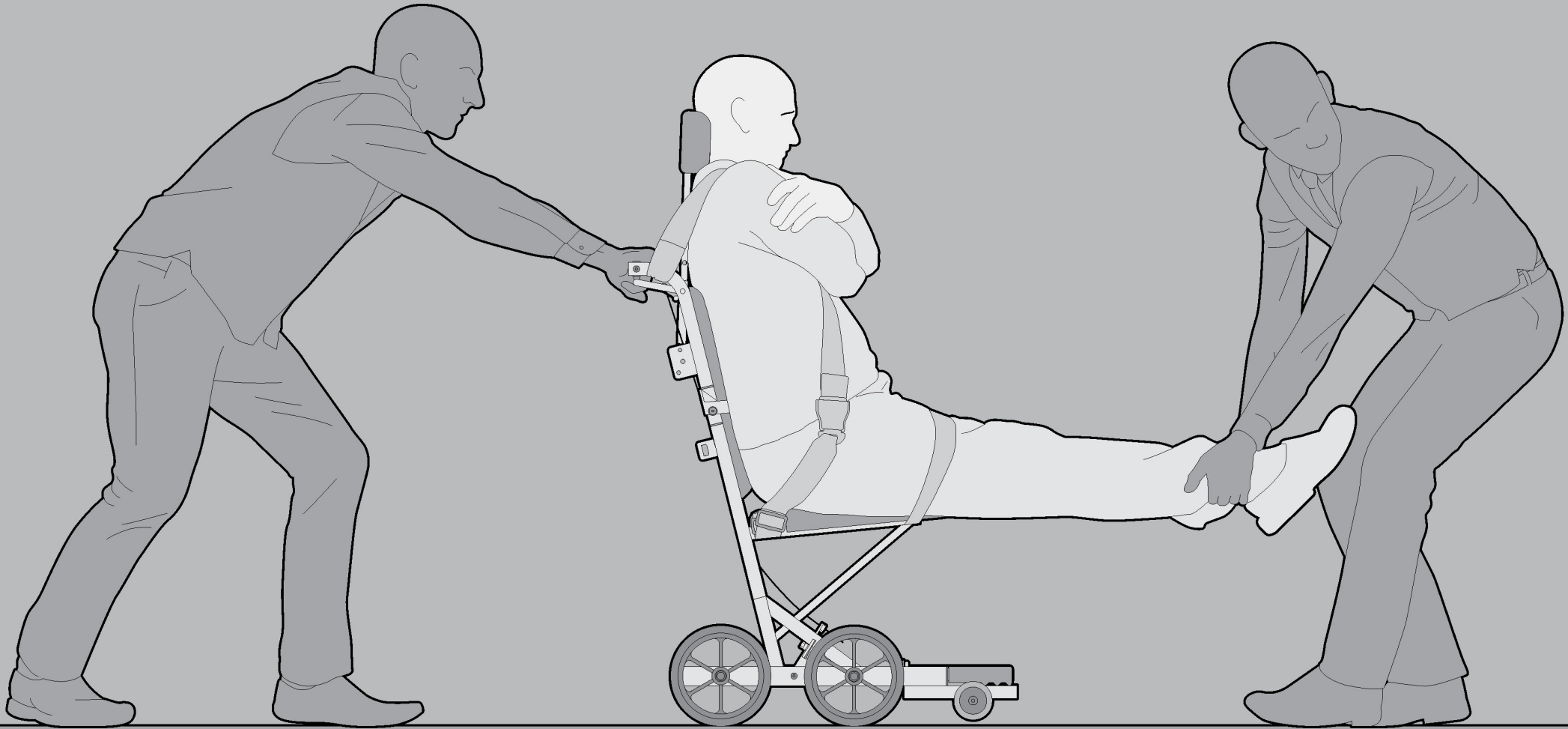

# Aircraft-compatible wheelchair



# Aircraft boarding using a personal aisle chair: Narrow accessory wheels









# Mechanical transfer lift

Overhead gantry-style boarding device

Lifts passenger from personal mobility device and then rotates passenger 90 degrees



# Boarding down the aisle

## Overhead gantry-style boarding device

Lifts passenger above the height of the arm support and narrows to move down the aisle

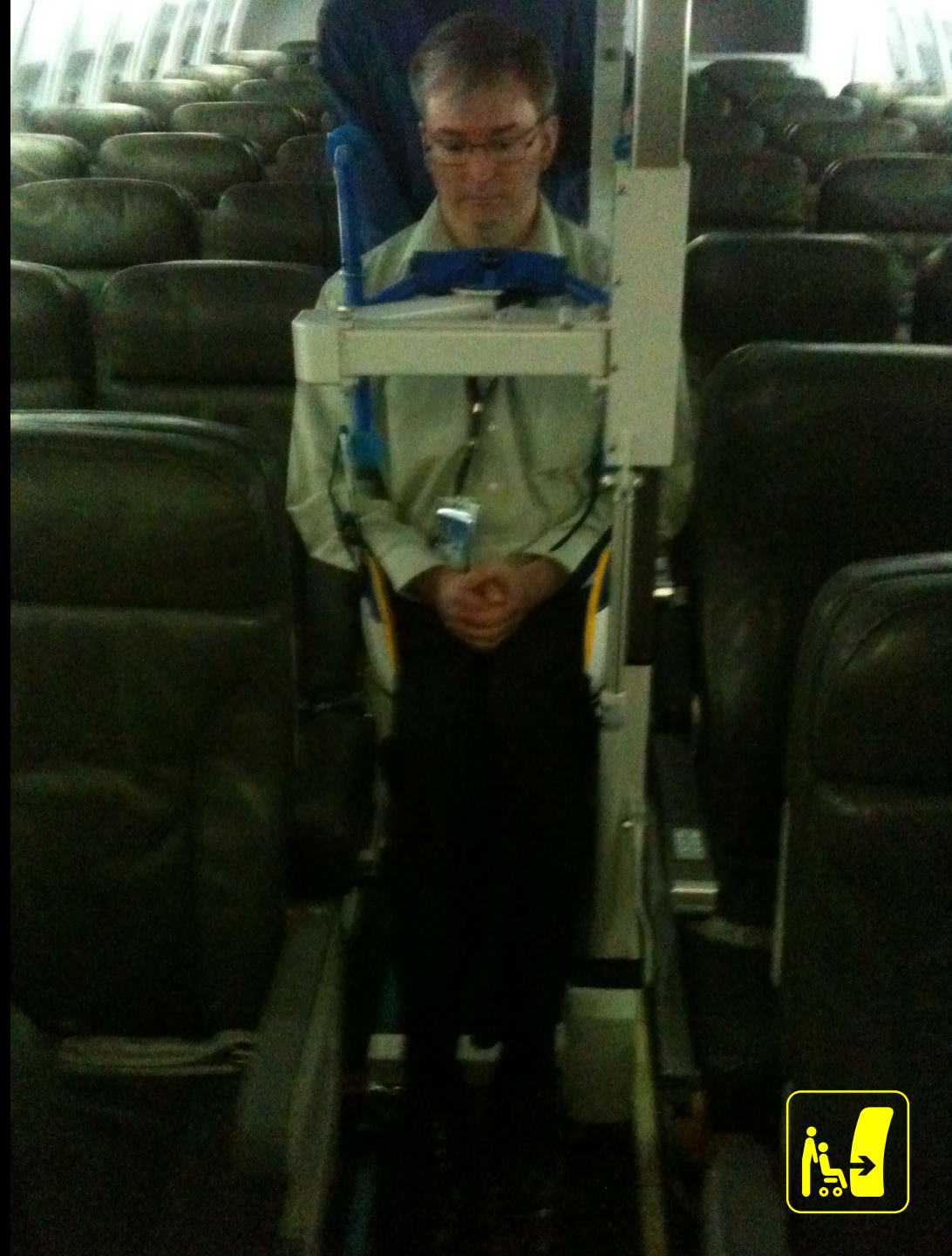







# Connections and Arrival

## Connections

# Things to think about

**Reassemble** wheelchair in jetway or meet transport WC

**Verify** wheelchair function

**Verify** departure gate and time

**Travel** to departure terminal and gate

**Obtain** food and water and visit restroom

**Check** in with departure gate and **verify** all information

**Notify** final destination transportation of any changes



Arrival at final destination

# Things to think about

**Reassemble** wheelchair in jetway or meet transport WC

**Verify** wheelchair function

**Visit** restroom

**Obtain** food and water

**Proceed** to baggage claim and/or ground transportation





Mishandling

# Examples of damage



# Examples of damage



# Examples of damage



# Examples of damage

Damage to drive wheel that  
broke off a powered wheelchair



# When wheelchair is damaged



Photo document damage



## Response to mishandling

# Wheelchair not loaded or damaged

### Options include...

- a) Continue flight to destination  
(and inform passenger of assistance available)
- b) Remain at connecting city until device arrives  
(carrier provides necessary assistance)
- c) Return to city of origin  
(carrier provides necessary assistance)



# Response to mishandling Wheelchair damaged

**Request notification** to downline station, flight attendants, and all air carrier agents

Prior to deplaning, **determine** appropriate seating and mobility solution

**Inspect** mobility device

Request point of **contact** for repairs at the baggage area

Discuss **corrective actions** necessary



## Response to mishandling

# Pressure relief and positioning

If you need of pressure relief and positioning, the following options should be considered...

Assistance **returning home**

Assistance **traveling to...**

an accessible hotel room

a medical facility

intended destination



# Response to mishandling

## Repair options

If the mobility device is damaged and repair is necessary...

Request the nearest appropriate mobility device  
**repair business provider** for assistance ASAP...

Repair

Replacement

Temporary replacement

Make a **worst-case plan** ahead of time





The Future

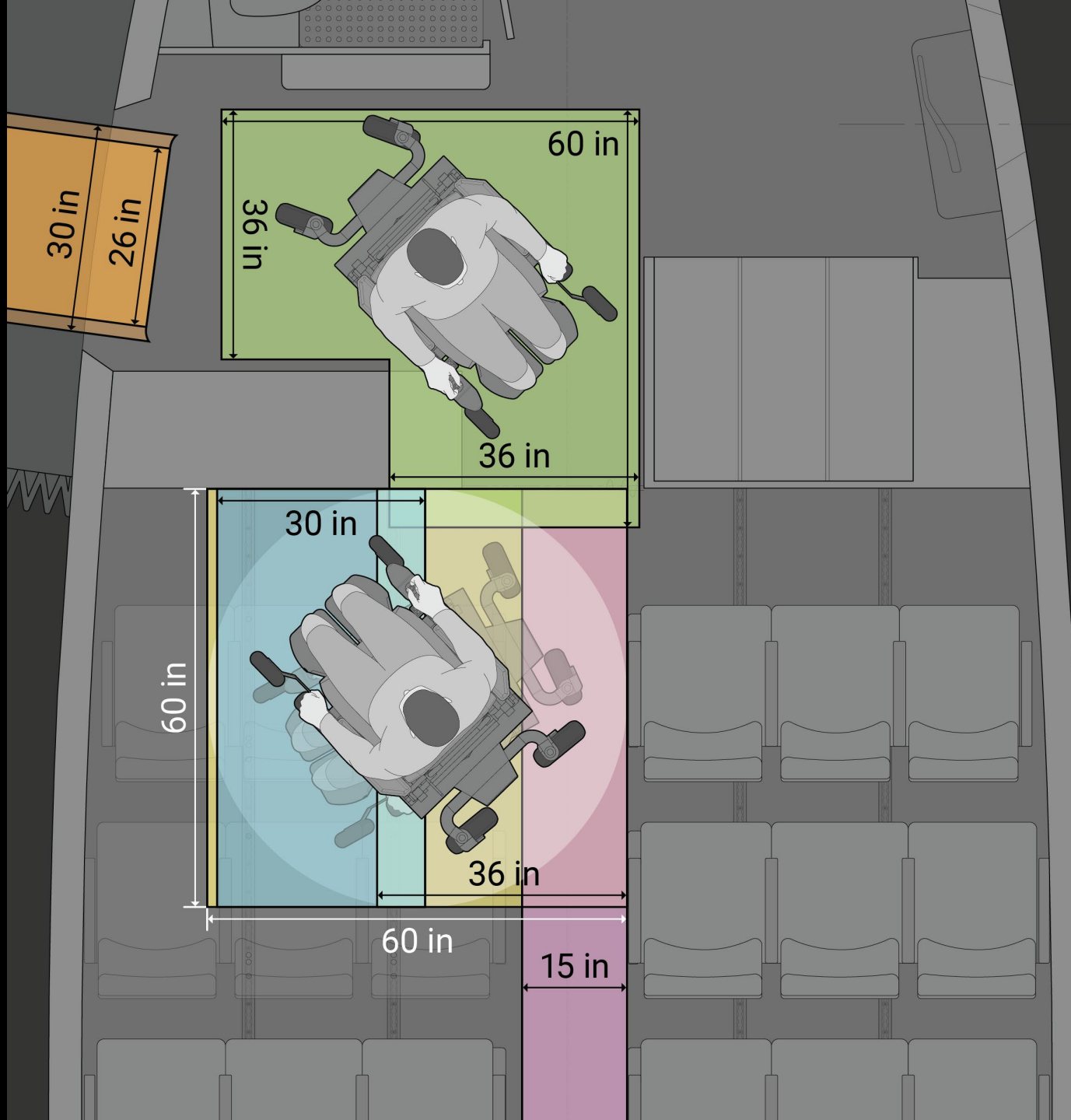

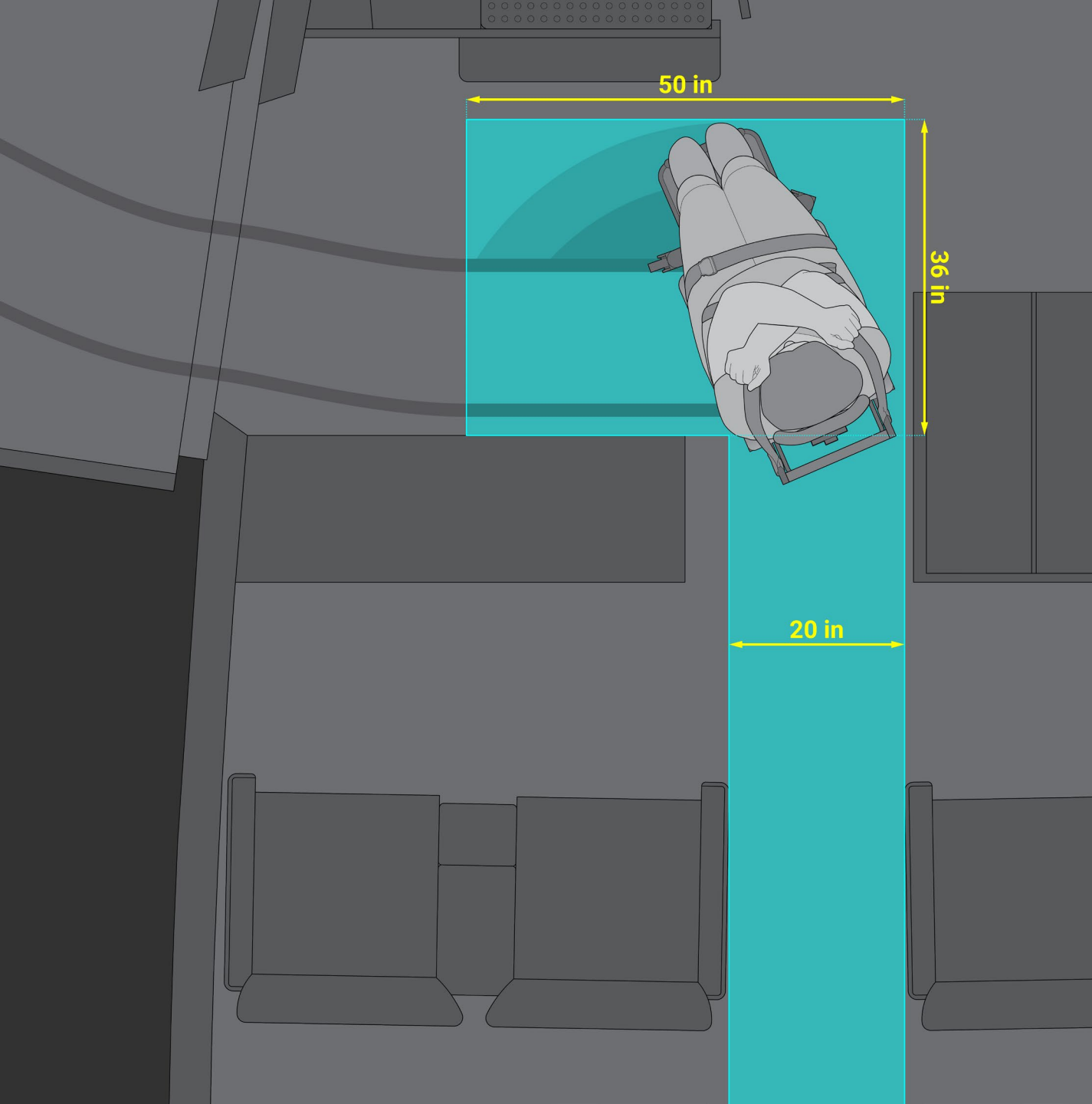

## Rear Wheel Pivot with Rotating Casters

**19.8 in** hip width

95<sup>th</sup> percentile  
US Female



# Device Comparison

95<sup>th</sup> percentile  
US Male

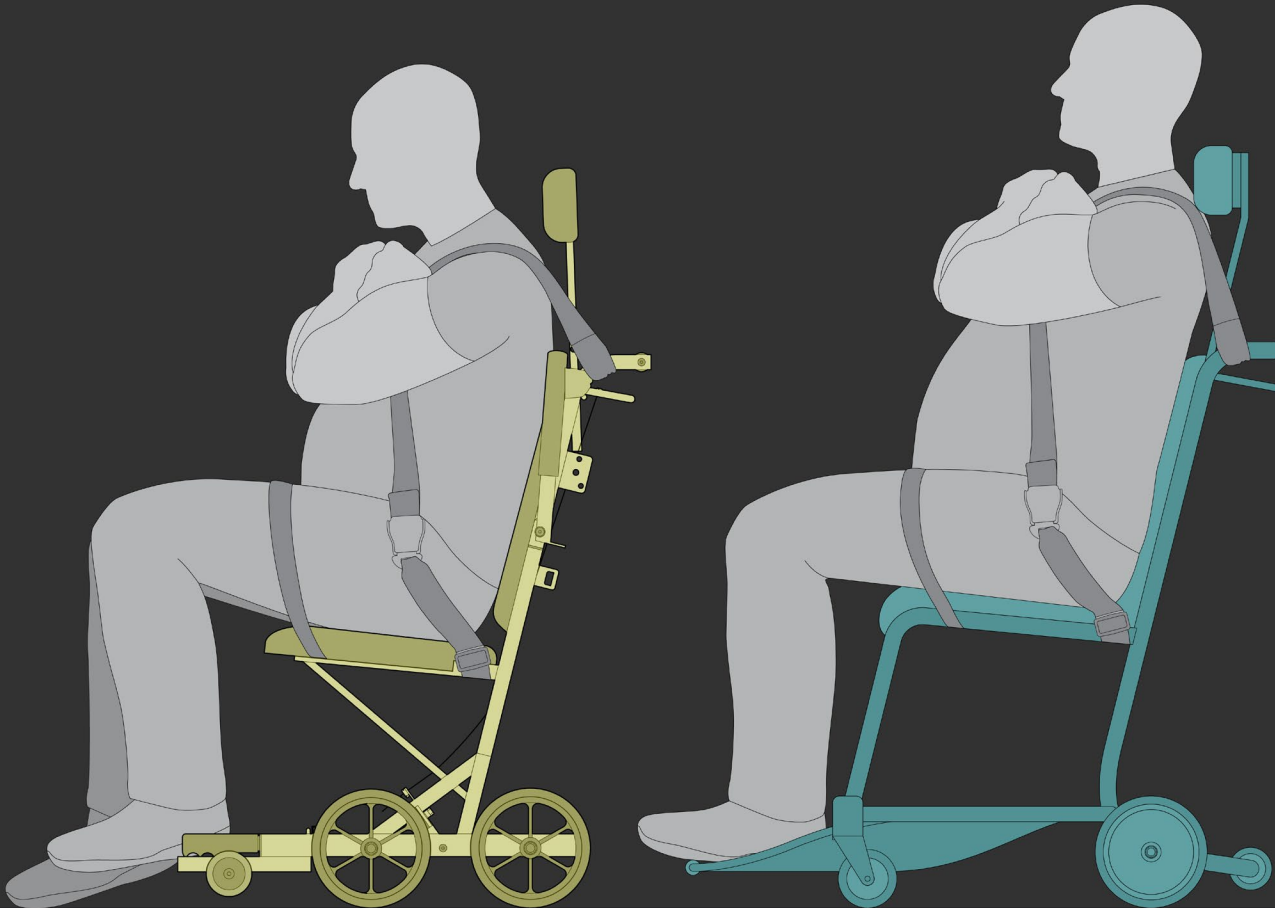



# beneficial designs

designing beyond the norm to meet the needs of all people

Peter W. Axelson MSME, ATP, RET

[peter@beneficialdesigns.com](mailto:peter@beneficialdesigns.com)

775.783.8822 voice

775.783.8823 fax

